











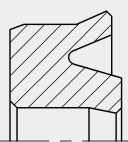



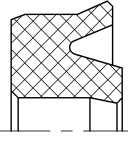





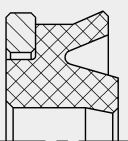



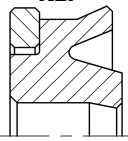



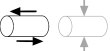

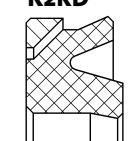

# Piston seals

Application	Profile	Description	Temperature	max.speed	max. Pressure	Material	
  		<b>hydraulic, single acting</b> asymmetric piston seal for standard applications. design provides stable fit in the housing, ultimate sealing effect over a wide temperature range. avoids extensive drag pressure. back-to-back arrangement with guide ring in between or for double acting pistons or to separate different fluids.	-30 °C ... +110 °C	0,5 m/s	400 bar (5800 psi)	ECOPUR	
			-20 °C ... +110 °C	0,5 m/s	400 bar (5800 psi)	H-ECOPUR	
			-20 °C ... +110 °C	0,7 m/s	400 bar (5800 psi)	S-ECOPUR	
			-50 °C ... +110 °C	0,5 m/s	400 bar (5800 psi)	T-ECOPUR	
			-30 °C ... +110 °C	0,5 m/s	400 bar (5800 psi)	G-ECOPUR	
  		<b>hydraulic, single acting</b> as profile K1, but more adaptation possibilities for diverse temperatures and media by selection of suitable seal material.	-30 °C ... +100 °C	0,5 m/s	160 bar (2300 psi)	ECORUBBER 1	
			-20 °C ... +200 °C	0,5 m/s	160 bar (2300 psi)	ECORUBBER 2	
			-50 °C ... +150 °C	0,5 m/s	160 bar (2300 psi)	ECORUBBER 3**	
			-25 °C ... +150 °C	0,5 m/s	160 bar (2300 psi)	ECORUBBER-H	
			-60 °C ... +200 °C	-	-	ECOSIL	
    		<b>hydraulic, single acting</b> as profile K2P, but more adaptation possibilities to diverse temperatures and media by selection of suitable seal material. K2 for standard housing design.	-30 °C ... +100 °C	0,5 m/s	250 bar (3600 psi)	ECORUBBER 1	Seal part
			-30 °C ... +100 °C	0,5 m/s	250 bar (3600 psi)	ECORUBBER 1	Back-up ring
			-20 °C ... +200 °C	0,5 m/s	250 bar (3600 psi)	ECORUBBER 2	ECOTAL
			-50 °C ... +100 °C	0,5 m/s	250 bar (3600 psi)	ECORUBBER 3**	ECOTAL
			-40 °C ... +100 °C	0,5 m/s	250 bar (3600 psi)	ECORUBBER 3**	ECOMID*
			-50 °C ... +150 °C	0,5 m/s	250 bar (3600 psi)	ECORUBBER 3**	ECOFLO II
			-25 °C ... +100 °C	0,5 m/s	250 bar (3600 psi)	ECORUBBER-H	ECOTAL
			-25 °C ... +100 °C	0,5 m/s	250 bar (3600 psi)	ECORUBBER-H	ECOMID*
			-25 °C ... +150 °C	0,5 m/s	250 bar (3600 psi)	ECORUBBER-H	ECOFLO II
  		<b>hydraulic, single acting</b> asymmetric piston seal for standard applications as K1, but due to design with active back-up ring suitable for higher pressure range or larger extrusion gaps. K2 for standard housing design.	-30 °C ... +100 °C	0,5 m/s	700 bar (10.000 psi)	ECOPUR	Seal part
			-20 °C ... +100 °C	0,5 m/s	700 bar (10.000 psi)	H-ECOPUR	Back-up ring
			-20 °C ... +100 °C	0,7 m/s	700 bar (10.000 psi)	S-ECOPUR	ECOTAL/ ECOMID*
			-40 °C ... +100 °C	0,5 m/s	700 bar (10.000 psi)	T-ECOPUR	
			-30 °C ... +100 °C	0,5 m/s	700 bar (10.000 psi)	G-ECOPUR	
  		<b>hydraulic, single acting</b> with active back-up ring suitable for high asymmetric piston seal for standard applications as K1, but due to design her pressure or larger extrusion gaps. K2PD for short housings.	-30 °C ... +100 °C	0,5 m/s	700 bar (10.000 psi)	ECOPUR	Seal part
			-20 °C ... +100 °C	0,5 m/s	700 bar (10.000 psi)	H-ECOPUR	Back-up ring
			-20 °C ... +100 °C	0,7 m/s	700 bar (10.000 psi)	S-ECOPUR	ECOTAL/ ECOMID*
			-40 °C ... +100 °C	0,5 m/s	700 bar (10.000 psi)	T-ECOPUR	
			-30 °C ... +100 °C	0,5 m/s	700 bar (10.000 psi)	G-ECOPUR	
    		<b>hydraulic, single acting</b> as profile K2P, but more adaptation possibilities to diverse temperatures and media by selection of suitable seal material. K2RD for short housings.	-30 °C ... +100 °C	0,5 m/s	250 bar (3600 psi)	ECORUBBER 1	Seal part
			-30 °C ... +100 °C	0,5 m/s	250 bar (3600 psi)	ECORUBBER 1	Back-up ring
			-20 °C ... +200 °C	0,5 m/s	250 bar (3600 psi)	ECORUBBER 2	ECOTAL
			-50 °C ... +100 °C	0,5 m/s	250 bar (3600 psi)	ECORUBBER 3**	ECOTAL
			-40 °C ... +100 °C	0,5 m/s	250 bar (3600 psi)	ECORUBBER 3**	ECOMID*
			-50 °C ... +150 °C	0,5 m/s	250 bar (3600 psi)	ECORUBBER 3**	ECOFLO II
			-25 °C ... +100 °C	0,5 m/s	250 bar (3600 psi)	ECORUBBER-H	ECOTAL
			-25 °C ... +100 °C	0,5 m/s	250 bar (3600 psi)	ECORUBBER-H	ECOMID*
			-25 °C ... +150 °C	0,5 m/s	250 bar (3600 psi)	ECORUBBER-H	ECOFLO II
  		<b>hydraulic, single acting</b> o-ring activated, asymmetrical piston seal. interference fit on inside diameter maintains stable fit in the housing. design provides ultimate sealing effect. especially suitable for short stroke applications (e.g. spindle seals, coupling actuators...)	-30 °C ... +100 °C	0,5 m/s	400 bar (5800 psi)	ECOPUR	Seal part
			-20 °C ... +100 °C	0,5 m/s	400 bar (5800 psi)	H-ECOPUR	O ring
			-30 °C ... +100 °C	0,5 m/s	400 bar (5800 psi)	T-ECOPUR	NBR (70 Sh A)
			-20 °C ... +100 °C	0,7 m/s	400 bar (5800 psi)	S-ECOPUR	NBR (70 Sh A)
			-30 °C ... +100 °C	0,5 m/s	400 bar (5800 psi)	G-ECOPUR	NBR (70 Sh A)
			-50 °C ... +100 °C	0,5 m/s	400 bar (5800 psi)	T-ECOPUR	MOV 70 / ECOSIL

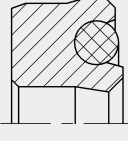
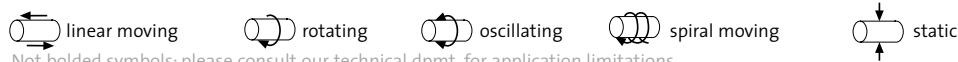

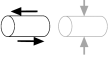
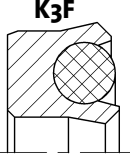
Not bolded symbols: please consult our technical dpmt. for application limitations

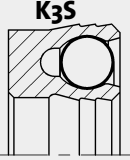
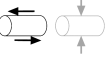
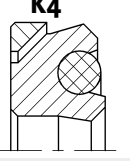
\* ECOTAL up to ø260 mm, ECOMID above ø260 mm  
 \*\* attention: not suitable for mineral oils!

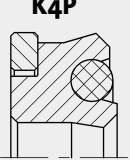
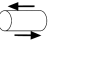
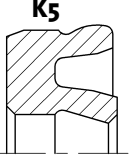
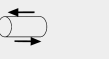
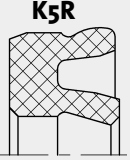
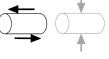
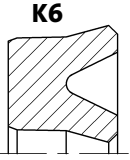
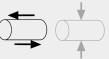
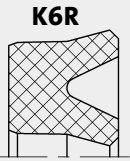

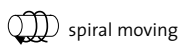
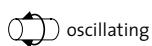
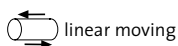







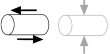
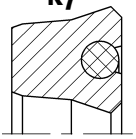

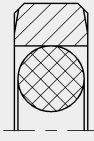

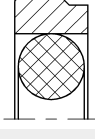
Application	Profile	Description	Temperature	max.speed	max. Pressure	Material		
		<b>PTFE-piston seal, single acting</b> O-Ring activated, asymmetrical PTFE piston seal, low friction and no stick-slip effect. good adaptation possibilities for diverse temperatures and media by selection of suitable O-Ring material, almost no dead spots as required for applications in food and pharma industry.	-20 °C ... +200 °C	1 m/s	100 bar (1450 psi)	<b>Seal part</b> ECOFLON 1	<b>O-Ring</b> FPM/FKM (75 Sh A)	
			-20 °C ... +200 °C	1 m/s	160 bar (2300 psi)	ECOFLON 2	FPM/FKM (75 Sh A)	
			-25 °C ... +150 °C	1 m/s	100 bar (1450 psi)	ECOFLON 1	ECORUBBER-H	
			-25 °C ... +150 °C	1 m/s	160 bar (2300 psi)	ECOFLON 2	ECORUBBER-H	
			-60 °C ... +80 °C	0,5 m/s	200 bar (2900 psi)	ECOPE	MVQ 70 / ECOSIL	
			-60 °C ... +200 °C	1 m/s	100 bar (1450 psi)	ECOFLON 1	MVQ 70 / ECOSIL	
			-60 °C ... +200 °C	1 m/s	160 bar (2300 psi)	ECOFLON 2	MVQ 70 / ECOSIL	
		<b>PTFE-piston seal, single acting</b> helicoil spring activated, asymmetrical PTFE piston seal, low friction and no stick-slip effect, excellent chemical and thermal resistance, mainly used in chemical, pharma and food industry or for valves.	-200 °C ... +260 °C	1 m/s	100 bar (1450 psi)	<b>Seal part</b> ECOFLON 1	<b>Spring</b> 1.4310	
			-200 °C ... +260 °C	1 m/s	160 bar (2300 psi)	ECOFLON 2	1.4310	
			-200 °C ... + 80 °C	0,5 m/s	200 bar (2900 psi)	ECOPE	1.4310	
		<b>hydraulic, single acting</b> asymmetric piston seal for standard applications as K3 but due to design with active back-up ring suitable for larger extrusion gaps. K4 for short housings	-30 °C ... +100 °C	0,5 m/s	700 bar (10.000 psi)	<b>Seal part</b> ECOUPUR	<b>O-ring</b>	<b>Back-up</b>
			-20 °C ... +100 °C	0,5 m/s	700 bar (10.000 psi)	H-ECOUPUR	NBR (70 Sh.A)	ECOTAL/ ECOMID*
			-30 °C ... +100 °C	0,5 m/s	700 bar (10.000 psi)	T-ECOUPUR		
			-20 °C ... +100 °C	0,7 m/s	700 bar (10.000 psi)	S-ECOUPUR		
			-30 °C ... +100 °C	0,5 m/s	700 bar (10.000 psi)	G-ECOUPUR		
		<b>hydraulic, single acting</b> asymmetric piston seal for standard applications as K3 but due to design with active back-up ring suitable for larger extrusion gaps or higher pressure. K4P for standard housing design	-30 °C ... +100 °C	0,5 m/s	700 bar (10.000 psi)	<b>Seal part</b> ECOUPUR	<b>O-ring</b>	<b>Back-up</b>
			-20 °C ... +100 °C	0,5 m/s	700 bar (10.000 psi)	H-ECOUPUR	NBR (70 Sh.A)	ECOTAL/ ECOMID*
			-30 °C ... +100 °C	0,5 m/s	700 bar (10.000 psi)	T-ECOUPUR		
			-20 °C ... +100 °C	0,7 m/s	700 bar (10.000 psi)	S-ECOUPUR		
			-30 °C ... +100 °C	0,5 m/s	700 bar (10.000 psi)	G-ECOUPUR		
		<b>pneumatic, single acting</b> asymmetric piston seal, extremely wear resistant, for use in lubricated or dry pneumatic applications. special design of sealing lip allows retention of initial lubricating film.	-30 °C ... +110 °C	1 m/s	25 bar (360 psi)	ECOUPUR		
			-20 °C ... +110 °C	1 m/s	25 bar (360 psi)	H-ECOUPUR		
			-20 °C ... +110 °C	2 m/s	25 bar (360 psi)	S-ECOUPUR		
			-50 °C ... +110 °C	1 m/s	25 bar (360 psi)	T-ECOUPUR		
			-30 °C ... +110 °C	1 m/s	25 bar (360 psi)	G-ECOUPUR		
		<b>pneumatic, single acting</b> asymmetric piston seal, good wear resistant, for use in lubricated or dry pneumatic applications. good adaptation possibilities for diverse temperatures and media by selection of suitable seal material. special design of sealing lip allows retention of initial lubricating film.	-30 °C ... + 80 °C	1 m/s	25 bar (360 psi)	ECORUBBER 1		
			-20 °C ... +200 °C	1 m/s	25 bar (360 psi)	ECORUBBER 2		
			-50 °C ... +150 °C	1 m/s	25 bar (360 psi)	ECORUBBER 3**		
			-25 °C ... +150 °C	1 m/s	25 bar (360 psi)	ECORUBBER-H		
		<b>hydraulic, single acting</b> symmetric piston seal for simple standard applications, not recommended for new designs (profile K1 preferred). also for larger cross section, easier to install.	-30 °C ... +110 °C	0,5 m/s	400 bar (5800 psi)	ECOUPUR		
			-20 °C ... +110 °C	0,5 m/s	400 bar (5800 psi)	H-ECOUPUR		
			-20 °C ... +110 °C	0,7 m/s	400 bar (5800 psi)	S-ECOUPUR		
			-50 °C ... +110 °C	0,5 m/s	400 bar (5800 psi)	T-ECOUPUR		
			-30 °C ... +110 °C	0,5 m/s	400 bar (5800 psi)	G-ECOUPUR		
		<b>hydraulic, single acting</b> as profile K6, but more adaptation possibilities for diverse temperatures and media by selection of suitable seal material. also for larger cross section, easier to install.	-30 °C ... +100 °C	0,5 m/s	160 bar (2300 psi)	ECORUBBER 1		
			-20 °C ... +200 °C	0,5 m/s	160 bar (2300 psi)	ECORUBBER 2		
			-50 °C ... +150 °C	0,5 m/s	160 bar (2300 psi)	ECORUBBER 3**		
			-25 °C ... +150 °C	0,5 m/s	160 bar (2300 psi)	ECORUBBER-H		
			-60 °C ... +200 °C	-	-	ECOSIL		

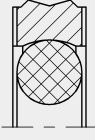

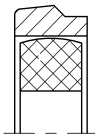
Not bolded symbols: please consult our technical dpmt. for application limitations

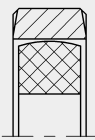
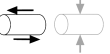
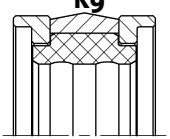
\* ECOTAL up to ø260 mm, ECOMID above ø260 mm

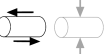
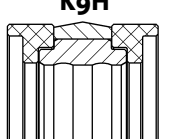
\*\* attention: not suitable for mineral oils!

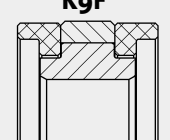

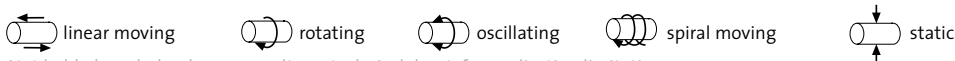







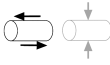

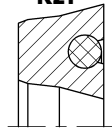
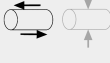

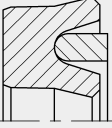



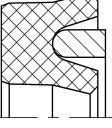



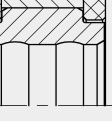
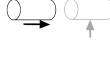

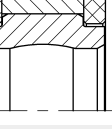
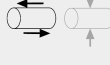
Application	Profile	Description	Temperature	max.speed	max. Pressure	Material		
		<b>hydraulic, single acting</b> O-Ring activated symmetric piston seal for simple standard applications, not recommended for new designs (profile K3 preferred)	-30 °C ... +100 °C	0,5 m/s	400 bar (5800 psi)	Seal part	O-ring	
			-20 °C ... +100 °C	0,5 m/s	400 bar (5800 psi)	ECOPUR	NBR (70 Sh.A)	
			-20 °C ... +100 °C	0,7 m/s	400 bar (5800 psi)	H-ECOPUR		
			-30 °C ... +100 °C	0,5 m/s	400 bar (5800 psi)	S-ECOPUR		
			-30 °C ... +100 °C	0,5 m/s	400 bar (5800 psi)	T-ECOPUR		
-30 °C ... +100 °C	0,5 m/s	400 bar (5800 psi)	G-ECOPUR					
		<b>hydraulic, double acting</b> O-Ring activated symmetric PTFE piston seal, low friction. for extreme low or high speed, suitable for positioning functions. for mobile hydraulics, machine tools, injection moulding machines, heavy hydraulics.	-30 °C ... +100 °C	10 m/s	400 bar (5800 psi)	Glide ring	O-ring	
			-20 °C ... +200 °C	10 m/s	400 bar (5800 psi)	ECOFILON 2/3/4	NBR (70 Sh.A) FPM/FKM (75) EPDM (70)** MVQ (70) MVQ 70 / ECOSIL	
			-50 °C ... +150 °C	10 m/s	400 bar (5800 psi)			
			-60 °C ... +200 °C	10 m/s	400 bar (5800 psi)			
			-60 °C ... +80 °C	10 m/s	400 bar (5800 psi)	ECOPE		
		<b>hydraulic, single acting</b> O-Ring activated asymmetric PTFE piston seal, low friction. for extreme low or high speed. suitable for positioning functions.	-30 °C ... +100 °C	10 m/s	400 bar (5800 psi)	Glide ring		
			-20 °C ... +200 °C	10 m/s	400 bar (5800 psi)	ECOFILON 2/3/4	NBR (70 Sh.A) FPM/FKM (75) EPDM (70)** MVQ (70) MVQ 70 / ECOSIL	
			-50 °C ... +150 °C	10 m/s	400 bar (5800 psi)			
			-60 °C ... +200 °C	10 m/s	400 bar (5800 psi)			
			-60 °C ... +80 °C	10 m/s	400 bar (5800 psi)	ECOPE		
		<b>hydraulic, double acting</b> O-Ring activated symmetric PU piston seal with excellent static and dynamic sealing capacity, extremely wear resistant.	-30 °C ... +100 °C	1 m/s	250 bar (3600 psi)	Glide ring		
			-20 °C ... +100 °C	1 m/s	250 bar (3600 psi)	ECOPUR	NBR 70Sh.A	
			-20 °C ... +100 °C	1 m/s	250 bar (3600 psi)	H-ECOPUR		
			-20 °C ... +100 °C	1,4 m/s	250 bar (3600 psi)	S-ECOPUR		
-30 °C ... +100 °C	1 m/s	250 bar (3600 psi)	T-ECOPUR					
		<b>hydraulic, single acting</b> profile ring-activated asymmetric PTFE piston seal, similar to K8E, but special heavy duty design. for heavy industry hydraulics or for special housing dimensions.	-30 °C ... +100 °C	10 m/s	400 bar (5800 psi)	Glide ring	Energizer	
			-20 °C ... +200 °C	10 m/s	400 bar (5800 psi)	ECOFILON 2, 3, 4	ECORUBBER 1 ECORUBBER 2 ECORUBBER 3** ECORUBBER-H	
			-50 °C ... +150 °C	10 m/s	400 bar (5800 psi)			
			-25 °C ... +150 °C	10 m/s	400 bar (5800 psi)			
-25 °C ... +150 °C	10 m/s	400 bar (5800 psi)						
		<b>hydraulic, double acting</b> profile ring-activated symmetric PTFE piston seal, similar to S9D, but special heavy duty design. for heavy industry hydraulics or for special housing dimensions.	-30 °C ... +100 °C	10 m/s	400 bar (5800 psi)	Glide ring	Energizer	
			-20 °C ... +200 °C	10 m/s	400 bar (5800 psi)	ECOFILON 2, 3, 4	ECORUBBER 1 ECORUBBER 2 ECORUBBER 3** ECORUBBER-H	
			-50 °C ... +150 °C	10 m/s	400 bar (5800 psi)			
			-25 °C ... +150 °C	10 m/s	400 bar (5800 psi)			
-25 °C ... +150 °C	10 m/s	400 bar (5800 psi)						
		<b>hydraulic, double acting</b> profile ring-activated compact piston seal with integrated guiding elements. excellent static sealing capacity. commonly used in standard cylinders.	-30 °C ... +100 °C	0,5 m/s	400 bar (5800 psi)	Seal	Energizer	Back-up ring
			-20 °C ... +100 °C	0,5 m/s	400 bar (5800 psi)	ECOPUR		
			-30 °C ... +100 °C	0,5 m/s	400 bar (5800 psi)	H-ECOPUR		
			-20 °C ... +100 °C	0,7 m/s	400 bar (5800 psi)	T-ECOPUR		
			-30 °C ... +100 °C	0,5 m/s	400 bar (5800 psi)	S-ECOPUR		
		<b>hydraulic, double acting</b> profile ring-activated compact piston seal with integrated guiding elements. excellent static and dynamic sealing capacity.	-30 °C ... +100 °C	0,5 m/s	400 bar (5800 psi)	Seal	Energizer	Back-up ring
			-20 °C ... +100 °C	0,5 m/s	400 bar (5800 psi)	ECOPUR		
			-30 °C ... +100 °C	0,5 m/s	400 bar (5800 psi)	H-ECOPUR		
			-20 °C ... +100 °C	0,7 m/s	400 bar (5800 psi)	T-ECOPUR		
			-30 °C ... +100 °C	0,5 m/s	400 bar (5800 psi)	S-ECOPUR		
		<b>hydraulic, double acting</b> profile ring-activated compact piston seal with integrated guiding elements. design for high pressure range, excellent static sealing capacity. mainly used in mining / tunneling industry.	-20 °C ... +100 °C	0,3 m/s	1500 bar (21700 psi)	Seal	Energizer	Back-up ring
			-30 °C ... +100 °C	0,3 m/s	1500 bar (21700 psi)	H-ECOPUR		
		<b>hydraulic, double acting</b> profile ring-activated compact PTFE piston seal with integrated guiding elements. low friction, good chemical and thermal resistance.	-30 °C ... +100 °C	1,5 m/s	500 bar (7200 psi)	Seal	Energizer	Back-up ring
			-30 °C ... +100 °C	1,5 m/s	500 bar (7200 psi)	ECOFILON 2		
			-20 °C ... +200 °C	1,5 m/s	400 bar (5800 psi)	ECOFILON 2		
			-20 °C ... +200 °C	1,5 m/s	400 bar (5800 psi)	ECOFILON 2		

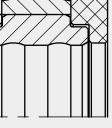
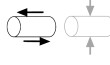

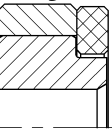
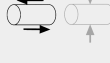

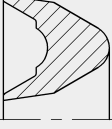
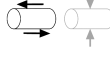

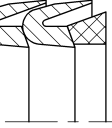
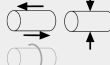

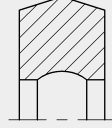





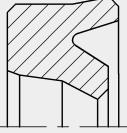
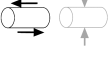

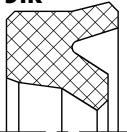

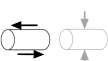
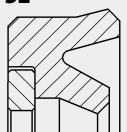
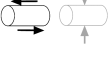
Not bolded symbols: please consult our technical dpmt. for application limitations

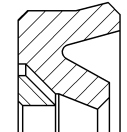
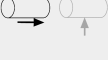
\* ECOTAL up to ø260 mm, ECOMID above ø260 mm  
\*\* attention: not suitable for mineral oils !

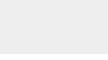
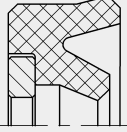
Application	Profile	Description	Temperature	max.speed	max. Pressure	Material		
		<b>hydraulic, single acting</b> chevron sealing set, machined surface design. in back-to-back arrangement with one intermediate chevron for double sided pressure activation, in single acting applications with more intermediate chevrons possible. for heavy industry hydraulics.	-30 °C ... +100 °C	0,5 m/s	500 bar (7200 psi)	K10	K 11	K 12
			-20 °C ... +100 °C	0,5 m/s	500 bar (7200 psi)			
			-40 °C ... +100 °C	0,5 m/s	500 bar (7200 psi)			
			-20 °C ... +100 °C	0,7 m/s	500 bar (7200 psi)			
			-30 °C ... +100 °C	0,5 m/s	250 bar (3600 psi)			
			-20 °C ... +200 °C	0,5 m/s	250 bar (3600 psi)			
			-50 °C ... +150 °C	0,5 m/s	250 bar (3600 psi)			
			-25 °C ... +150 °C	0,5 m/s	250 bar (3600 psi)			
		<b>hydraulic, single acting</b> chevron sealing set, parted surface design. in back-to-back arrangement with one intermediate chevron for double sided pressure activation, in single acting applications with more intermediate chevrons possible. for heavy industry hydraulics.	-30 °C ... +100 °C	0,5 m/s	500 bar (7200 psi)	K 10	K 11	K 12
			-20 °C ... +100 °C	0,5 m/s	500 bar (7200 psi)			
			-40 °C ... +100 °C	0,5 m/s	500 bar (7200 psi)			
			-20 °C ... +100 °C	0,7 m/s	500 bar (7200 psi)			
			-30 °C ... +100 °C	0,5 m/s	250 bar (3600 psi)			
			-20 °C ... +200 °C	0,5 m/s	250 bar (3600 psi)			
			-50 °C ... +150 °C	0,5 m/s	250 bar (3600 psi)			
			-25 °C ... +150 °C	0,5 m/s	250 bar (3600 psi)			
		<b>hydraulic, single acting</b> chevron sealing set, design with flexible sealing lips, good sealing ability in higher pressure range. for heavy industry hydraulics, water-hydraulic systems	-30 °C ... +100 °C	0,5 m/s	600 bar (8700 psi)	K 13	K 14	K 15
			-20 °C ... +100 °C	0,5 m/s	600 bar (8700 psi)			
			-40 °C ... +100 °C	0,5 m/s	600 bar (8700 psi)			
			-20 °C ... +100 °C	0,7 m/s	600 bar (8700 psi)			
			-20 °C ... +100 °C	0,7 m/s	600 bar (8700 psi)			
		<b>hydraulic/pneumatic, single acting</b> simple cup seal, usually fixed on the piston by means of a clamping plate. mainly used for replacement in old hydraulic and pneumatic cylinders or for low-grade secondary applications. also used for food filling / portioning equipment.	-30 °C ... +110 °C	0,5 m/s	160 bar (2300 psi)	ECOPUR	K 11	K 12
			-20 °C ... +110 °C	0,5 m/s	160 bar (2300 psi)			
			-50 °C ... +110 °C	0,5 m/s	160 bar (2300 psi)			
			-20 °C ... +110 °C	0,7 m/s	160 bar (2300 psi)			
			-30 °C ... +110 °C	0,5 m/s	160 bar (2300 psi)			
			-30 °C ... +100 °C	0,5 m/s	160 bar (2300 psi)			
			-25 °C ... +150 °C	0,5 m/s	160 bar (2300 psi)			
			-20 °C ... +200 °C	0,5 m/s	160 bar (2300 psi)			
			-50 °C ... +150 °C	0,5 m/s	160 bar (2300 psi)			
			-50 °C ... +150 °C	0,5 m/s	160 bar (2300 psi)			
		<b>hydraulic/pneumatic, single acting</b> simple cup seal, usually fixed on the piston by means of a clamping plate. mainly used for replacement in old hydraulic and pneumatic cylinders or for low-grade secondary applications. also used for food filling / portioning equipment.	-30 °C ... +110 °C	0,5 m/s	160 bar (2300 psi)	ECOPUR	K 11	K 12
			-20 °C ... +110 °C	0,5 m/s	160 bar (2300 psi)			
			-50 °C ... +110 °C	0,5 m/s	160 bar (2300 psi)			
			-20 °C ... +110 °C	0,7 m/s	160 bar (2300 psi)			
			-30 °C ... +110 °C	0,5 m/s	160 bar (2300 psi)			
			-30 °C ... +100 °C	0,5 m/s	160 bar (2300 psi)			
			-25 °C ... +150 °C	0,5 m/s	160 bar (2300 psi)			
			-20 °C ... +200 °C	0,5 m/s	160 bar (2300 psi)			
			-50 °C ... +150 °C	0,5 m/s	160 bar (2300 psi)			
			-50 °C ... +150 °C	0,5 m/s	160 bar (2300 psi)			
		<b>hydraulic, double acting</b> space saving, compact piston seal with integrated guiding elements. excellent static sealing capacity, suitable for small housings.	-30 °C ... +100 °C	0,5 m/s	250 bar (3600 psi)	Seal part	Back-up ring	
			-20 °C ... +100 °C	0,5 m/s	250 bar (3600 psi)			
			-40 °C ... +100 °C	0,5 m/s	250 bar (3600 psi)			
			-20 °C ... +100 °C	0,7 m/s	250 bar (3600 psi)			
			-20 °C ... +100 °C	0,7 m/s	250 bar (3600 psi)			
		<b>hydraulic, double acting</b> space saving, compact piston seal with integrated guiding elements. excellent static sealing capacity, good adaptation possibilities for diverse temperatures and media by selection of suitable material. suitable for small housings.	-30 °C ... +100 °C	0,5 m/s	250 bar (3600 psi)	Seal part	Back-up ring	
			-30 °C ... +100 °C	0,5 m/s	250 bar (3600 psi)			
			-20 °C ... +200 °C	0,5 m/s	250 bar (3600 psi)			
			-20 °C ... +200 °C	0,5 m/s	250 bar (3600 psi)			
			-20 °C ... +200 °C	0,5 m/s	250 bar (3600 psi)			
		<b>PTFE-piston seal, single acting</b> finger-spring activated, asymmetrical PTFE piston seal, low friction and good dry running properties, excellent chemical and thermal resistance, mainly used in chemical, pharma and food industry.	-200 °C ... +260 °C	15 m/s	100 bar (1450 psi)	Seal part	Spring	
			-200 °C ... +260 °C	15 m/s	160 bar (2300 psi)			
			-200 °C ... +260 °C	15 m/s	160 bar (2300 psi)			
			-200 °C ... +80 °C	15 m/s	200 bar (2900 psi)			
			-200 °C ... +80 °C	15 m/s	200 bar (2900 psi)			
		<b>hydraulic, double acting</b> space saving, compact piston seal, suitable for standard O-Ring housings. advantage compared to O-Ring: integrated active back-up rings for high pressure, design with interference fit on outside diameter prevents twisting in dynamic applications.	-30 °C ... +100 °C	0,5 m/s	700 bar (10.000 psi)	Seal part	Back-up ring	
			-25 °C ... +100 °C	0,5 m/s	700 bar (10.000 psi)			
			-20 °C ... +200 °C	0,5 m/s	700 bar (10.000 psi)			
			-25 °C ... +150 °C	0,5 m/s	700 bar (10.000 psi)			
			-25 °C ... +150 °C	0,5 m/s	700 bar (10.000 psi)			

Application	Profile	Description	Temperature	max. speed	max. Pressure	Material			
  		<b>hydraulic, single acting</b> O-Ring activated symmetric rod seal with sharp-edged sealing lips, good sealing effect for high viscosity fluids, not recommended for new designs (profile S3 preferred).	-30 °C ... +100 °C	0,5 m/s	400 bar (5800 psi)	ECOPUR	Seal part	O-ring	
			-20 °C ... +100 °C	0,5 m/s	400 bar (5800 psi)	H-ECOPUR			
			-30 °C ... +100 °C	0,5 m/s	400 bar (5800 psi)	T-ECOPUR			
			-20 °C ... +100 °C	0,7 m/s	400 bar (5800 psi)	S-ECOPUR			
			-30 °C ... +100 °C	0,5 m/s	400 bar (5800 psi)	G-ECOPUR			
  		<b>hydraulic, single acting</b> symmetric piston seal with support ring for simple applications to serve repair purpose, not recommended for new designs (profile K1 preferred). retainer ring in angled design possible.	-30 °C ... +100 °C	0,5 m/s	400 bar (5800 psi)	ECOPUR	Seal part	Support ring	
			-20 °C ... +100 °C	0,5 m/s	400 bar (5800 psi)	H-ECOPUR			
			-40 °C ... +100 °C	0,5 m/s	400 bar (5800 psi)	T-ECOPUR			
			-20 °C ... +100 °C	0,7 m/s	400 bar (5800 psi)	S-ECOPUR			
			-30 °C ... +100 °C	0,5 m/s	400 bar (5800 psi)	G-ECOPUR			
  		<b>hydraulic, single acting</b> symmetric piston seal as K22, but more adaptation possibilities for diverse temperatures and media by selection of suitable seal material.. retainer ring in angled design possible.	-30 °C ... +100 °C	0,5 m/s	160 bar (2300 psi)	ECORUBBER 1	Seal part	Support ring	
			-30 °C ... +100 °C	0,5 m/s	160 bar (2300 psi)	ECORUBBER 1			
			-20 °C ... +200 °C	0,5 m/s	160 bar (2300 psi)	ECORUBBER 2			
			-50 °C ... +100 °C	0,5 m/s	160 bar (2300 psi)	ECORUBBER 3**			
			-40 °C ... +100 °C	0,5 m/s	160 bar (2300 psi)	ECORUBBER 3**			
			-50 °C ... +150 °C	0,5 m/s	160 bar (2300 psi)	ECORUBBER 3**			
			-25 °C ... +100 °C	0,5 m/s	160 bar (2300 psi)	ECORUBBER-H			
			-25 °C ... +100 °C	0,5 m/s	160 bar (2300 psi)	ECORUBBER-H			
			-25 °C ... +150 °C	0,5 m/s	160 bar (2300 psi)	ECORUBBER-H			
			-25 °C ... +150 °C	0,5 m/s	160 bar (2300 psi)	ECORUBBER-H			
  		<b>hydraulic, double acting</b> profile ring-activated compact piston seal with integrated back-up rings, excellent static sealing capacity. external guiding elements required.	-30 °C ... +100 °C	0,5 m/s	400 bar (5800 psi)	ECOPUR	Seal	Energizer	Back-up rings
			-20 °C ... +100 °C	0,5 m/s	400 bar (5800 psi)	H-ECOPUR			
			-30 °C ... +100 °C	0,5 m/s	400 bar (5800 psi)	T-ECOPUR			
			-20 °C ... +100 °C	0,7 m/s	400 bar (5800 psi)	S-ECOPUR			
			-30 °C ... +100 °C	0,5 m/s	400 bar (5800 psi)	G-ECOPUR			
  		<b>hydraulic, double acting</b> profile ring-activated compact piston seal with integrated back-up rings. excellent static and dynamic sealing capacity. external guiding elements required.	-30 °C ... +100 °C	0,5 m/s	400 bar (5800 psi)	ECOPUR	Seal	Energizer	Back-up rings
			-20 °C ... +100 °C	0,5 m/s	400 bar (5800 psi)	H-ECOPUR			
			-30 °C ... +100 °C	0,5 m/s	400 bar (5800 psi)	T-ECOPUR			
			-20 °C ... +100 °C	0,7 m/s	400 bar (5800 psi)	S-ECOPUR			
			-30 °C ... +100 °C	0,5 m/s	400 bar (5800 psi)	G-ECOPUR			
  		<b>hydraulic, double acting</b> profile ring-activated compact piston seal with integrated back-up rings. design for high pressure range, excellent static sealing capacity. mainly used in mining / tunneling industry. external guiding elements required.	-20 °C ... +100 °C	0,3 m/s	1500 bar (21000 psi)	H-ECOPUR	Seal	Energizer	Back-up rings
			-30 °C ... +100 °C	0,3 m/s	1500 bar (21000 psi)	G-ECOPUR			
  		<b>hydraulic, double acting</b> profile ring-activated compact PTFE piston seal with integrated back-up rings. low friction, good chemical and thermal resistance. external guiding elements required.	-30 °C ... +100 °C	1,5 m/s	500 bar (7200 psi)	ECOFLO 2	Seal	Energizer	Back-up rings
			-30 °C ... +100 °C	1,5 m/s	500 bar (7200 psi)	ECOFLO 2			
			-20 °C ... +200 °C	1,5 m/s	400 bar (5800 psi)	ECOFLO 2			
			-20 °C ... +200 °C	1,5 m/s	400 bar (5800 psi)	ECOFLO 2			
			-20 °C ... +200 °C	1,5 m/s	400 bar (5800 psi)	ECOFLO 2			
			-20 °C ... +200 °C	1,5 m/s	400 bar (5800 psi)	ECOFLO 4			
  		<b>hydraulic, single acting</b> chevron ring with flexible lip design. replacement part for standard commercial housings (male and female adapter mainly made of metal).	-30 °C ... +110 °C	0,5 m/s	500 bar (7200 psi)	ECOPUR	Seal		
			-20 °C ... +110 °C	0,5 m/s	500 bar (7200 psi)	H-ECOPUR			
			-50 °C ... +110 °C	0,5 m/s	500 bar (7200 psi)	T-ECOPUR			
			-20 °C ... +110 °C	0,7 m/s	500 bar (7200 psi)	S-ECOPUR			
			-30 °C ... +110 °C	0,5 m/s	500 bar (7200 psi)	G-ECOPUR			
			-30 °C ... +100 °C	0,5 m/s	250 bar (3600 psi)	ECORUBBER 1			
			-20 °C ... +200 °C	0,5 m/s	250 bar (3600 psi)	ECORUBBER 2			
			-50 °C ... +150 °C	0,5 m/s	250 bar (3600 psi)	ECORUBBER 3**			
			-25 °C ... +150 °C	0,5 m/s	250 bar (3600 psi)	ECORUBBER H			
  		<b>hydraulic, single acting</b> chevron sealing set, design with extremely flexible sealing lips for difficult operating conditions like bad guiding, large tolerance range. available as total chevron sealing set as well as intermediate chevrons only (in case of metal male and female adapters).	-30 °C ... +100 °C	0,5 m/s	500 bar (7200 psi)	ECOPUR	Seal	Collar	Back-up ring
			-20 °C ... +100 °C	0,5 m/s	500 bar (7200 psi)	H-ECOPUR			
			-40 °C ... +100 °C	0,5 m/s	500 bar (7200 psi)	T-ECOPUR			
			-20 °C ... +100 °C	0,7 m/s	500 bar (7200 psi)	S-ECOPUR			
			-30 °C ... +100 °C	0,5 m/s	500 bar (7200 psi)	G-ECOPUR			
  		<b>hydraulic, double acting</b> compact piston seal with almost no dead spots as required for applications in food and pharma industry, also commonly used as O-Ring replacement, because design with interference fit on outside diameter maintains non-twisting in dynamic applications.	-30 °C ... +110 °C	0,4 m/s	400 bar (5800 psi)	ECOPUR	Seal part		
			-20 °C ... +110 °C	0,4 m/s	400 bar (5800 psi)	H-ECOPUR			
			-50 °C ... +110 °C	0,4 m/s	400 bar (5800 psi)	T-ECOPUR			
			-20 °C ... +110 °C	0,5 m/s	400 bar (5800 psi)	S-ECOPUR			
			-30 °C ... +110 °C	0,4 m/s	400 bar (5800 psi)	G-ECOPUR			

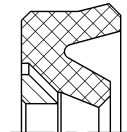

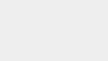
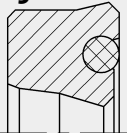

# Rod Seals

Application	Profile	Description	Temperature	max.speed	max. Pressure	Material	
  		<b>hydraulic, single acting</b> asymmetric rod seal for standard applications. interference fit on outside diameter maintains stable fit in the housing. design provides ultimate sealing effect over a wide temperature range and good backpumping ability. also used as secondary seal in combination with PTFE-seal type S9.	-30 °C ... +110 °C	0,5 m/s	400 bar (5800 psi)	ECOPUR	
			-20 °C ... +110 °C	0,5 m/s	400 bar (5800 psi)	H-ECOPUR	
			-20 °C ... +110 °C	0,7 m/s	400 bar (5800 psi)	S-ECOPUR	
			-50 °C ... +110 °C	0,5 m/s	400 bar (5800psi)	T-ECOPUR	
			-30 °C ... +110 °C	0,5 m/s	400 bar (5800 psi)	G-ECOPUR	
  		<b>hydraulic, single acting</b> as profile S01-P, but more adaptation possibilities for diverse temperatures and media by selection of suitable seal material.	-30 °C ... +100 °C	0,5 m/s	160 bar (2300 psi)	ECORUBBER 1	
			-20 °C ... +200 °C	0,5 m/s	160 bar (2300 psi)	ECORUBBER 2	
			-50 °C ... +150 °C	0,5 m/s	160 bar (2300 psi)	ECORUBBER 3**	
			-25 °C ... +150 °C	0,5 m/s	160 bar (2300 psi)	ECORUBBER-H	
			-60 °C ... +200 °C	-	-	ECOSIL	
  		<b>hydraulic, single acting</b> asymmetric rod seal for standard applications as S1, but due to design with active back-up ring suitable for larger extrusion gaps or higher pressure range. S02-P for standard housing design	-30 °C ... +100 °C	0,5 m/s	700 bar (10.000 psi)	ECOPUR	Seal part Back-up ring ECOTAL/ ECOMID*
			-20 °C ... +100 °C	0,5 m/s	700 bar (10.000 psi)	H-ECOPUR	
			-20 °C ... +100 °C	0,7 m/s	700 bar (10.000 psi)	S-ECOPUR	
			-40 °C ... +100 °C	0,5 m/s	700 bar (10.000 psi)	T-ECOPUR	
			-30 °C ... +100 °C	0,5 m/s	700 bar (10.000 psi)	G-ECOPUR	
  		<b>hydraulic, single acting</b> asymmetric rod seal for standard applications as S1, but due to design with active back-up ring suitable for larger extrusion gaps or higher pressure range. S2PD for short housings	-30 °C ... +100 °C	0,5 m/s	700 bar (10.000 psi)	ECOPUR	Seal part Back-up ring ECOTAL/ ECOMID*
			-20 °C ... +100 °C	0,5 m/s	700 bar (10.000 psi)	H-ECOPUR	
			-20 °C ... +100 °C	0,7 m/s	700 bar (10.000 psi)	S-ECOPUR	
			-40 °C ... +100 °C	0,5 m/s	700 bar (10.000 psi)	T-ECOPUR	
			-30 °C ... +100 °C	0,5 m/s	700 bar (10.000 psi)	G-ECOPUR	
  		<b>hydraulic, single acting</b> as profile S2, but more adaptation possibilities for diverse temperatures and media by selection of suitable seal material. S2R for standard housing design	-30 °C ... +100 °C	0,5 m/s	250 bar (3600 psi)	ECORUBBER 1	Seal part Back-up ring ECOTAL* ECOMID* ECOFLON 2 ECOTAL* ECOMID* ECOFLON 2 ECOTAL* ECOMID* ECOFLON 2 ECOTAL* ECOMID* ECOFLON 2
			-30 °C ... +100 °C	0,5 m/s	250 bar (3600 psi)	ECORUBBER 1	
			-20 °C ... +200 °C	0,5 m/s	250 bar (3600 psi)	ECORUBBER 2	
			-50 °C ... +100 °C	0,5 m/s	250 bar (3600 psi)	ECORUBBER 3**	
			-40 °C ... +100 °C	0,5 m/s	250 bar (3600 psi)	ECORUBBER 3**	
			-50 °C ... +150 °C	0,5 m/s	250 bar (3600 psi)	ECORUBBER 3**	
			-25 °C ... +100 °C	0,5 m/s	250 bar (3600 psi)	ECORUBBER-H	
			-25 °C ... +100 °C	0,5 m/s	250 bar (3600 psi)	ECORUBBER H	
			-25 °C ... +150 °C	0,5 m/s	250 bar (3600 psi)	ECORUBBER H	
  		<b>hydraulic, single acting</b> as profile S02-P, but more adaptation possibilities for diverse temperatures and media by selection of suitable seal material. S2RD for short housings	-30 °C ... +100 °C	0,5 m/s	250 bar (3600 psi)	ECORUBBER 1	Seal part Back-up ring ECOTAL* ECOMID* ECOFLON 2 ECOTAL* ECOMID* ECOFLON 2 ECOTAL* ECOMID* ECOFLON 2
			-30 °C ... +100 °C	0,5 m/s	250 bar (3600 psi)	ECORUBBER 1	
			-20 °C ... +200 °C	0,5 m/s	250 bar (3600 psi)	ECORUBBER 2	
			-50 °C ... +100 °C	0,5 m/s	250 bar (3600 psi)	ECORUBBER 3**	
			-40 °C ... +100 °C	0,5 m/s	250 bar (3600 psi)	ECORUBBER 3**	
			-50 °C ... +150 °C	0,5 m/s	250 bar (3600 psi)	ECORUBBER 3**	
			-25 °C ... +100 °C	0,5 m/s	250 bar (3600 psi)	ECORUBBER-H	
			-25 °C ... +100 °C	0,5 m/s	250 bar (3600 psi)	ECORUBBER H	
			-25 °C ... +150 °C	0,5 m/s	250 bar (3600 psi)	ECORUBBER H	
 		<b>hydraulic, single acting</b> O-Ring activated, asymmetrical rod seal. interference fit on outside diameter maintains stable fit in the housing. design provides ultimate sealing effect. especially suitable for short stroke applications (e.g. spindle seals, coupling actuators...)	-30 °C ... +100 °C	0,5 m/s	400 bar (5800 psi)	ECOPUR	Seal part O ring NBR (70 Sh A) NBR (70 Sh A) NBR (70 Sh A) NBR (70 Sh A) NBR (70 Sh A)
			-20 °C ... +100 °C	0,5 m/s	400 bar (5800 psi)	H-ECOPUR	
			-30 °C ... +100 °C	0,5 m/s	400 bar (5800 psi)	T-ECOPUR	
			-20 °C ... +100 °C	0,7 m/s	400 bar (5800 psi)	S-ECOPUR	
			-30 °C ... +100 °C	0,5 m/s	400 bar (5800 psi)	G-ECOPUR	

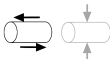
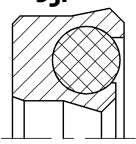

Not bolded symbols: please consult our technical dpmt. for application limitations

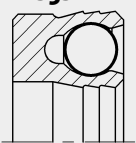
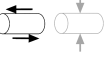
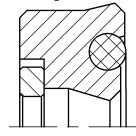
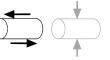
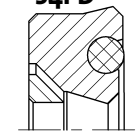
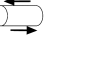
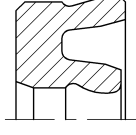
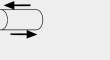
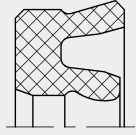
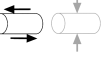
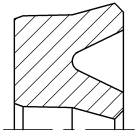
\* ECOTAL up to ø260 mm, ECOMID above ø260 mm  
 \*\* attention: not suitable for mineral oils !

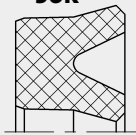

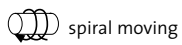
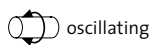
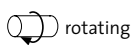
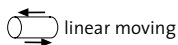

Application	Profile	Description	Temperature	max.speed	max. Pressure	Material		
		<b>PTFE-rodseal, single acting</b> O-Ring activated, asymmetrical PTFE rod seal, low friction, good dry running properties and adaptation possibilities for diverse temperatures and media by selection of suitable O-Ring material, almost no dead spots as required for applications in food & pharma industry.	-20 °C ... +200 °C	1 m/s	100 bar (1450 psi)	<b>Seal part</b> ECOFLON 1	<b>O-Ring</b> FPM/FKM (75 Sh A)	
			-20 °C ... +200 °C	1 m/s	160 bar (2300 psi)	ECOFLON 2	FPM/FKM (75 Sh A)	
			-25 °C ... +150 °C	1 m/s	100 bar (1450 psi)	ECOFLON 1	ECORUBBER-H	
			-25 °C ... +150 °C	1 m/s	160 bar (2300 psi)	ECOFLON 2	ECORUBBER-H	
			-60 °C ... +80 °C	0,5 m/s	200 bar (2900 psi)	ECOPE	MVQ 70 / ECOSIL	
			-60 °C ... +200 °C	1 m/s	100 bar (1450 psi)	ECOFLON 1	MVQ 70 / ECOSIL	
			-60 °C ... +200 °C	1 m/s	160 bar (2300 psi)	ECOFLON 2	MVQ 70 / ECOSIL	
		<b>PTFE-rodseal, single acting</b> helicoil spring activated, asymmetrical PTFE rod seal, low friction and good dry running properties, excellent chemical and thermal resistance, mainly used in chemical, pharma and food industry.	-200 °C ... +260 °C	1 m/s	100 bar (1450 psi)	<b>Seal part</b> ECOFLON 1	<b>Spring</b> 1.4310	
			-200 °C ... +260 °C	1 m/s	160 bar (2300 psi)	ECOFLON 2	1.4310	
			-200 °C ... + 80 °C	0,5 m/s	200 bar (2900 psi)	ECOPE	1.4310	
		<b>hydraulic, single acting</b> asymmetric rod seal for standard applications as S3, but due to design with active back-up ring suitable for larger extrusion gaps or higher pressure range. S04-P for standard housing design	-30 °C ... +100 °C	0,5 m/s	700 bar (10.000 psi)	<b>Seal part</b> ECOPUR	<b>O-ring</b> NBR (70 Sh.A)	<b>Back-up</b> ECOTAL/ ECOMID*
			-20 °C ... +100 °C	0,5 m/s	700 bar (10.000 psi)	H-ECOPUR		
			-30 °C ... +100 °C	0,5 m/s	700 bar (10.000 psi)	T-ECOPUR		
			-20 °C ... +100 °C	0,7 m/s	700 bar (10.000 psi)	S-ECOPUR		
			-30 °C ... +100 °C	0,5 m/s	700 bar (10.000 psi)	G-ECOPUR		
		<b>hydraulic, single acting</b> asymmetric rod seal for standard applications as S3, but due to design with active back-up ring suitable for larger extrusion gaps or higher pressure range. S4PD for short housings.	-30 °C ... +100 °C	0,5 m/s	700 bar (10.000 psi)	<b>Seal part</b> ECOPUR	<b>O-ring</b> NBR (70 Sh.A)	<b>Back-up</b> ECOTAL/ ECOMID*
			-20 °C ... +100 °C	0,5 m/s	700 bar (10.000 psi)	H-ECOPUR		
			-30 °C ... +100 °C	0,5 m/s	700 bar (10.000 psi)	T-ECOPUR		
			-20 °C ... +100 °C	0,7 m/s	700 bar (10.000 psi)	S-ECOPUR		
			-30 °C ... +100 °C	0,5 m/s	700 bar (10.000 psi)	G-ECOPUR		
		<b>pneumatic, single acting</b> asymmetric rod seal, extremely wear resistant, for use in lubricated or dry pneumatic applications. special design of sealing lip allows retention of initial lubricating film.	-30 °C ... +110 °C	1 m/s	25 bar (360 psi)	ECOPUR		
			-20 °C ... +110 °C	1 m/s	25 bar (360 psi)	H-ECOPUR		
			-20 °C ... +110 °C	2 m/s	25 bar (360 psi)	S-ECOPUR		
			-50 °C ... +110 °C	1 m/s	25 bar (360 psi)	T-ECOPUR		
			-30 °C ... +110 °C	1 m/s	25 bar (360 psi)	G-ECOPUR		
		<b>pneumatic, single acting</b> as profile S5R, good wear resistance and adaptation possibilities for diverse temperatures and media by selection of suitable seal material. special design of sealing lip allows retention of initial lubricating film.	-30 °C ... +80 °C	1 m/s	25 bar (360 psi)	ECORUBBER 1		
			-20 °C ... +200 °C	1 m/s	25 bar (360 psi)	ECORUBBER 2		
			-50 °C ... +150 °C	1 m/s	25 bar (360 psi)	ECORUBBER 3**		
			-25 °C ... +150 °C	1 m/s	25 bar (360 psi)	ECORUBBER-H		
		<b>hydraulic, single acting</b> symmetric rod seal for simple standard applications, not recommended for new designs (profile S1 should be preferred).	-30 °C ... +110 °C	0,5 m/s	400 bar (5800 psi)	ECOPUR		
			-20 °C ... +110 °C	0,5 m/s	400 bar (5800 psi)	H-ECOPUR		
			-20 °C ... +110 °C	0,7 m/s	400 bar (5800 psi)	S-ECOPUR		
			-50 °C ... +110 °C	0,5 m/s	400 bar (5800 psi)	T-ECOPUR		
			-30 °C ... +110 °C	0,5 m/s	400 bar (5800 psi)	G-ECOPUR		
		<b>hydraulic, single acting</b> as profile S6, but more adaptation possibilities for diverse temperatures and media by selection of suitable seal material.	-30 °C ... +100 °C	0,5 m/s	160 bar (2300 psi)	ECORUBBER 1		
			-20 °C ... +200 °C	0,5 m/s	160 bar (2300 psi)	ECORUBBER 2		
			-50 °C ... +150 °C	0,5 m/s	160 bar (2300 psi)	ECORUBBER 3**		
			-25 °C ... +150 °C	0,5 m/s	160 bar (2300 psi)	ECORUBBER-H		
			-60 °C ... +200 °C	-	-	ECOSIL		

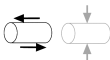
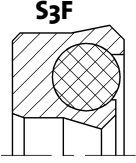
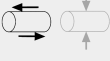
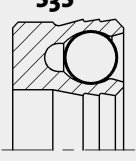
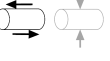
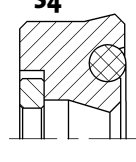

Not bolded symbols: please consult our technical dpmt. for application limitations

\* ECOTAL up to ø260 mm, ECOMID above ø260 mm

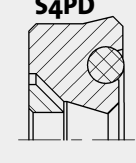
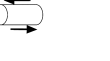
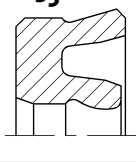
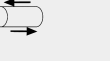
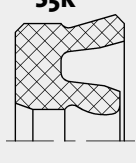
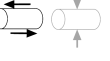
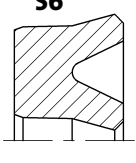

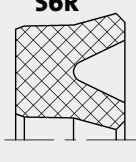
\*\* attention: not suitable for mineral oils !

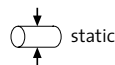
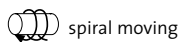
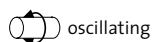
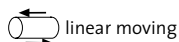
Application	Profile	Description	Temperature	max.speed	max. Pressure	Material		
		<b>PTFE-rodseal, single acting</b> O-Ring activated, asymmetrical PTFE rod seal, low friction, good dry running properties and adaptation possibilities for diverse temperatures and media by selection of suitable O-Ring material, almost no dead spots as required for applications in food & pharma industry.	-20 °C ... +200 °C	1 m/s	100 bar (1450 psi)	<b>Seal part</b> ECOFLON 1	<b>O-Ring</b> FPM/FKM (75 ShA)	
			-20 °C ... +200 °C	1 m/s	160 bar (2300 psi)	ECOFLON 2	FPM/FKM (75 ShA)	
			-25 °C ... +150 °C	1 m/s	100 bar (1450 psi)	ECOFLON 1	ECORUBBER-H	
			-25 °C ... +150 °C	1 m/s	160 bar (2300 psi)	ECOFLON 2	ECORUBBER-H	
			-60 °C ... +80 °C	0,5 m/s	200 bar (2900 psi)	ECOPE	MVQ 70 / ECOSIL	
			-60 °C ... +200 °C	1 m/s	100 bar (1450 psi)	ECOFLON 1	MVQ 70 / ECOSIL	
		<b>PTFE-rodseal, single acting</b> helicoil spring activated, asymmetrical PTFE rod seal, low friction and good dry running properties, excellent chemical and thermal resistance, mainly used in chemical, pharma and food industry.	-200 °C ... +260 °C	1 m/s	100 bar (1450 psi)	<b>Seal part</b> ECOFLON 1	<b>Spring</b> 1.4310	
			-200 °C ... +260 °C	1 m/s	160 bar (2300 psi)	ECOFLON 2	1.4310	
			-200 °C ... + 80 °C	0,5 m/s	200 bar (2900 psi)	ECOPE	1.4310	
		<b>hydraulic, single acting</b> asymmetric rod seal for standard applications as S3 but due to design with active back-up ring suitable for larger extrusion gaps or higher pressure range. S4 for standard housing design	-30 °C ... +100 °C	0,5 m/s	700 bar (10.000 psi)	<b>Seal part</b> ECOPUR	<b>O-ring</b> NBR (70 Sh.A)	<b>Back-up</b> ECOTAL/ ECOMID*
			-20 °C ... +100 °C	0,5 m/s	700 bar (10.000 psi)	H-ECOPUR		
			-30 °C ... +100 °C	0,5 m/s	700 bar (10.000 psi)	T-ECOPUR		
			-20 °C ... +100 °C	0,7 m/s	700 bar (10.000 psi)	S-ECOPUR		
			-30 °C ... +100 °C	0,5 m/s	700 bar (10.000 psi)	G-ECOPUR		
		<b>hydraulic, single acting</b> asymmetric rod seal for standard applications as S3 but due to design with active back-up ring suitable for larger extrusion gaps or higher pressure range. S4PD for short housings.	-30 °C ... +100 °C	0,5 m/s	700 bar (10.000 psi)	<b>Seal part</b> ECOPUR	<b>O-ring</b> NBR (70 Sh.A)	<b>Back-up</b> ECOTAL/ ECOMID*
			-20 °C ... +100 °C	0,5 m/s	700 bar (10.000 psi)	H-ECOPUR		
			-30 °C ... +100 °C	0,5 m/s	700 bar (10.000 psi)	T-ECOPUR		
			-20 °C ... +100 °C	0,7 m/s	700 bar (10.000 psi)	S-ECOPUR		
			-30 °C ... +100 °C	0,5 m/s	700 bar (10.000 psi)	G-ECOPUR		
		<b>pneumatic, single acting</b> asymmetric rod seal, extremely wear resistant, for use in lubricated or dry pneumatic applications. special design of sealing lip allows retention of initial lubricating film.	-30 °C ... +110 °C	1 m/s	25 bar (360 psi)	ECOPUR		
			-20 °C ... +110 °C	1 m/s	25 bar (360 psi)	H-ECOPUR		
			-20 °C ... +110 °C	2 m/s	25 bar (360 psi)	S-ECOPUR		
			-50 °C ... +110 °C	1 m/s	25 bar (360 psi)	T-ECOPUR		
			-30 °C ... +110 °C	1 m/s	25 bar (360 psi)	G-ECOPUR		
		<b>pneumatic, single acting</b> as profile S5R, good wear resistance and adaptation possibilities for diverse temperatures and media by selection of suitable seal material. special design of sealing lip allows retention of initial lubricating film.	-30 °C ... +80 °C	1 m/s	25 bar (360 psi)	ECORUBBER 1		
			-20 °C ... +200 °C	1 m/s	25 bar (360 psi)	ECORUBBER 2		
			-50 °C ... +150 °C	1 m/s	25 bar (360 psi)	ECORUBBER 3**		
			-25 °C ... +150 °C	1 m/s	25 bar (360 psi)	ECORUBBER-H		
		<b>hydraulic, single acting</b> symmetric rod seal for simple standard applications, not recommended for new designs (profile S1 should be preferred).	-30 °C ... +110 °C	0,5 m/s	400 bar (5800 psi)	ECOPUR		
			-20 °C ... +110 °C	0,5 m/s	400 bar (5800 psi)	H-ECOPUR		
			-20 °C ... +110 °C	0,7 m/s	400 bar (5800 psi)	S-ECOPUR		
			-50 °C ... +110 °C	0,5 m/s	400 bar (5800 psi)	T-ECOPUR		
			-30 °C ... +110 °C	0,5 m/s	400 bar (5800 psi)	G-ECOPUR		
		<b>hydraulic, single acting</b> as profile S6, but more adaptation possibilities for diverse temperatures and media by selection of suitable seal material.	-30 °C ... +100 °C	0,5 m/s	160 bar (2300 psi)	ECORUBBER 1		
			-20 °C ... +200 °C	0,5 m/s	160 bar (2300 psi)	ECORUBBER 2		
			-50 °C ... +150 °C	0,5 m/s	160 bar (2300 psi)	ECORUBBER 3**		
			-25 °C ... +150 °C	0,5 m/s	160 bar (2300 psi)	ECORUBBER-H		
			-60 °C ... +200 °C	-	-	ECOSIL		



Not bolded symbols: please consult our technical dpmt. for application limitations

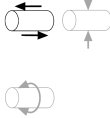
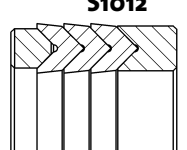
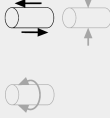
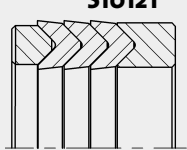
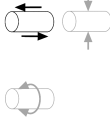
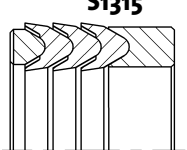

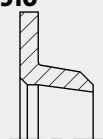
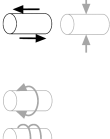
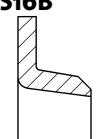
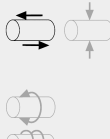
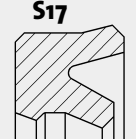
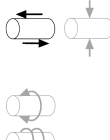
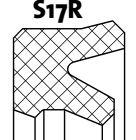
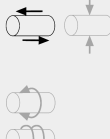
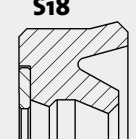
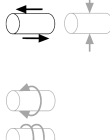
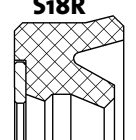

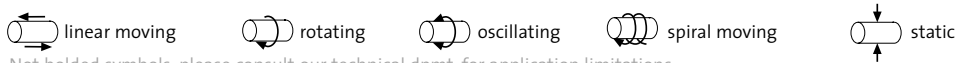
\* ECOTAL up to ø260 mm, ECOMID above ø260 mm  
\*\* attention: not suitable for mineral oils !

Application	Profile	Description	Temperature	max.speed	max. Pressure	Material
		<b>hydraulic, single acting</b> chevron sealing set, parting surface design. for heavy industry hydraulics.	-30 °C ... +100 °C	0,5 m/s	500 bar (7200 psi)	S10 S11 S12 ECOTAL/ ECOMID* ECO- FLON 2
			-20 °C ... +100 °C	0,5 m/s	500 bar (7200 psi)	
			-40 °C ... +100 °C	0,5 m/s	500 bar (7200 psi)	
			-20 °C ... +100 °C	0,7 m/s	500 bar (7200 psi)	
			-30 °C ... +100 °C	0,5 m/s	500 bar (7200 psi)	
			-30 °C ... +100 °C	0,5 m/s	250 bar (3600 psi)	
			-20 °C ... +200 °C	0,5 m/s	250 bar (3600 psi)	
			-50 °C ... +150 °C	0,5 m/s	250 bar (3600 psi)	
-25 °C ... +150 °C	0,5 m/s	250 bar (3600 psi)				
		<b>hydraulic, single acting</b> chevron sealing set, machined surface design. for heavy industry hydraulics.	-30 °C ... +100 °C	0,5 m/s	500 bar (7200 psi)	S10 S11 S12 ECOTAL/ ECOMID* ECO- FLON 2
			-20 °C ... +100 °C	0,5 m/s	500 bar (7200 psi)	
			-40 °C ... +100 °C	0,5 m/s	500 bar (7200 psi)	
			-20 °C ... +100 °C	0,7 m/s	500 bar (7200 psi)	
			-30 °C ... +100 °C	0,5 m/s	500 bar (7200 psi)	
			-30 °C ... +100 °C	0,5 m/s	250 bar (3600 psi)	
			-20 °C ... +200 °C	0,5 m/s	250 bar (3600 psi)	
			-50 °C ... +150 °C	0,5 m/s	250 bar (3600 psi)	
-25 °C ... +150 °C	0,5 m/s	250 bar (3600 psi)				
		<b>hydraulic, single acting</b> chevron sealing set, design with flexible sealing lips, good sealing ability in higher pressure range. for heavy industry hydraulics, water-hydraulic systems.	-30 °C ... +100 °C	0,5 m/s	600 bar (8700 psi)	S13-T S14-T S15-T ECOTAL/ ECOMID*
			-20 °C ... +100 °C	0,5 m/s	600 bar (8700 psi)	
			-40 °C ... +100 °C	0,5 m/s	600 bar (8700 psi)	
			-20 °C ... +100 °C	0,7 m/s	600 bar (8700 psi)	
			-30 °C ... +100 °C	0,5 m/s	600 bar (8700 psi)	
		<b>hydraulic/pneumatic, single acting</b> simple hat seal, usually fixed in housing with clamp flange. mainly used for replacement in old hydraulic and pneumatic cylinders or for secondary applications.	-30 °C ... +110 °C	0,5 m/s	160 bar (2300 psi)	ECOPUR H-ECOPUR T-ECOPUR S-ECOPUR ECORUBBER 1 ECORUBBER-H ECORUBBER 2 ECORUBBER 3**
			-20 °C ... +110 °C	0,5 m/s	160 bar (2300 psi)	
			-50 °C ... +110 °C	0,5 m/s	160 bar (2300 psi)	
			-20 °C ... +110 °C	0,7 m/s	160 bar (2300 psi)	
			-30 °C ... +100 °C	0,5 m/s	160 bar (2300 psi)	
			-25 °C ... +150 °C	0,5 m/s	160 bar (2300 psi)	
			-20 °C ... +200 °C	0,5 m/s	160 bar (2300 psi)	
-50 °C ... +150 °C	0,5 m/s	160 bar (2300 psi)				
		<b>hydraulic/pneumatic, single acting</b> simple hat seal, usually fixed in housing with clamp flange. mainly used for replacement in old hydraulic and pneumatic cylinders or for secondary applications.	-30 °C ... +110 °C	0,5 m/s	160 bar (2300 psi)	ECOPUR H-ECOPUR T-ECOPUR S-ECOPUR ECORUBBER 1 ECORUBBER-H ECORUBBER 2 ECORUBBER 3**
			-20 °C ... +110 °C	0,5 m/s	160 bar (2300 psi)	
			-50 °C ... +110 °C	0,5 m/s	160 bar (2300 psi)	
			-20 °C ... +110 °C	0,7 m/s	160 bar (2300 psi)	
			-30 °C ... +100 °C	0,5 m/s	160 bar (2300 psi)	
			-25 °C ... +150 °C	0,5 m/s	160 bar (2300 psi)	
			-20 °C ... +200 °C	0,5 m/s	160 bar (2300 psi)	
-50 °C ... +150 °C	0,5 m/s	160 bar (2300 psi)				
		<b>hydraulic, single acting</b> asymmetric rod seal with additional sealing- respectively stabilizing lip. interference fit on outside diameter maintains stable fit in the housing. design mainly used for telescopic cylinders, mobile hydraulic or for special housing dimensions.	-30 °C ... +110 °C	0,5 m/s	400 bar (5800 psi)	ECOPUR H-ECOPUR S-ECOPUR T-ECOPUR G-ECOPUR
			-20 °C ... +110 °C	0,5 m/s	400 bar (5800 psi)	
			-20 °C ... +110 °C	0,7 m/s	400 bar (5800 psi)	
			-50 °C ... +110 °C	0,5 m/s	400 bar (5800 psi)	
			-30 °C ... +110 °C	0,5 m/s	400 bar (5800 psi)	
		<b>hydraulic, single acting</b> as profile S17, but more adaptation possibilities for diverse temperatures and media by selection of suitable seal material.	-30 °C ... +110 °C	0,5 m/s	160 bar (2300 psi)	ECORUBBER 1 ECORUBBER 2 ECORUBBER 3** ECORUBBER-H
			-20 °C ... +110 °C	0,5 m/s	160 bar (2300 psi)	
			-50 °C ... +150 °C	0,5 m/s	160 bar (2300 psi)	
			-25 °C ... +150 °C	0,5 m/s	160 bar (2300 psi)	
		<b>hydraulic, single acting</b> asymmetric rod seal as S17, but due to design with active back-up ring suitable for larger extrusion gaps or higher pressure range.	-30 °C ... +100 °C	0,5 m/s	600 bar (8700 psi)	Seal part Back-up ring ECOTAL/ ECOMID*
			-20 °C ... +100 °C	0,5 m/s	600 bar (8700 psi)	
			-20 °C ... +100 °C	0,7 m/s	600 bar (8700 psi)	
			-40 °C ... +100 °C	0,5 m/s	600 bar (8700 psi)	
			-30 °C ... +100 °C	0,5 m/s	600 bar (8700 psi)	
		<b>hydraulic, single acting</b> asymmetric rod seal with additional sealing- respectively stabilizing lip and back ring. good adaptation possibilities for diverse temperatures and media by selection of suitable seal material, due to design with active back-up ring suitable for larger extrusion gaps or higher pressure range.	-30 °C ... +100 °C	0,5 m/s	250 bar (3600 psi)	Seal part Back-up ring ECOTAL/ ECOMID ECOFLON 2
			-30 °C ... +100 °C	0,5 m/s	250 bar (3600 psi)	
			-20 °C ... +200 °C	0,5 m/s	250 bar (3600 psi)	
			-40 °C ... +100 °C	0,5 m/s	250 bar (3600 psi)	
			-40 °C ... +100 °C	0,5 m/s	250 bar (3600 psi)	
			-50 °C ... +150 °C	0,5 m/s	250 bar (3600 psi)	
			-20 °C ... +100 °C	0,5 m/s	250 bar (3600 psi)	
			-20 °C ... +100 °C	0,5 m/s	250 bar (3600 psi)	
			-20 °C ... +150 °C	0,5 m/s	250 bar (3600 psi)	

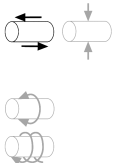
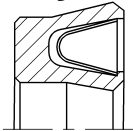
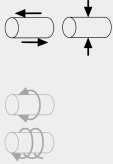
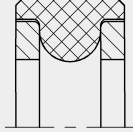
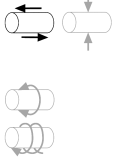
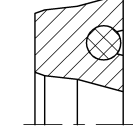
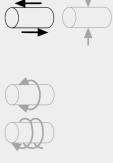
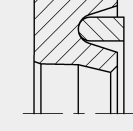
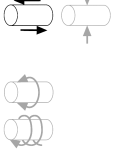
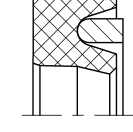
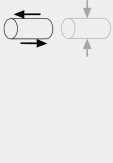
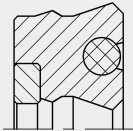
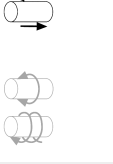
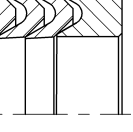
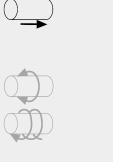

Not bolded symbols: please consult our technical dpmt. for application limitations

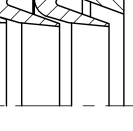
\* ECOTAL up to ø260 mm, ECOMID above ø260 mm  
 \*\* attention: not suitable for mineral oils !



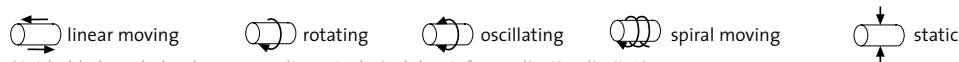







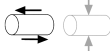

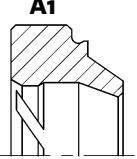



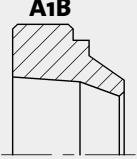



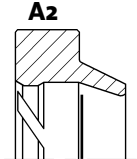

Application	Profile	Description	Temperature	max.speed	max. Pressure	Material
		<b>PTFE-rodseal, single acting</b> finger spring activated, asymmetrical PTFE rod seal, low friction and good dry running properties, excellent chemical and thermal resistance, mainly used in chemical, pharma and food industry.	-200 °C ... +260 °C	15 m/s	100 bar (1450 psi)	<b>Seal part</b> ECOFILON 1 1.4310
			-200 °C ... +260 °C	15 m/s	160 bar (2300 psi)	<b>Spring</b> ECOFILON 2 1.4310
			-200 °C ... +260 °C	15 m/s	160 bar (2300 psi)	ECOFILON 3 1.4310
			-200 °C ... +80 °C	15 m/s	200 bar (2900 psi)	ECOPE 1.4310
		<b>hydraulic, double acting</b> space saving, compact rod seal, fits standard O-Ring housings. advantage compared to O-Ring: integrated active back-up rings for high pressure, design with interference fit on outside diameter maintains non-twisting in dynamic applications.	-30 °C ... +100 °C	0,5 m/s	700 bar (10000 psi)	<b>Seal part</b> ECORUBBER 1 ECOTAL/
			-20 °C ... +100 °C	0,5 m/s	700 bar (10000 psi)	ECORUBBER-H ECOMID*
			-20 °C ... +200 °C	0,5 m/s	700 bar (10000 psi)	ECORUBBER 2 ECOPAEK/
			-25 °C ... +150 °C	0,5 m/s	700 bar (10000 psi)	ECORUBBER-H ECOFLON
		<b>hydraulic, single acting</b> O-Ring activated symmetric rod seal with sharp-edged sealing lips, good sealing effect for high viscosity fluids, not recommended for new designs (profile S3 preferred).	-30 °C ... +100 °C	0,5 m/s	400 bar (5800 psi)	<b>Seal part</b> ECOPUR <b>O-ring</b>
			-20 °C ... +100 °C	0,5 m/s	400 bar (5800 psi)	H-ECOPUR NBR (70 Sh.A)
			-30 °C ... +100 °C	0,5 m/s	400 bar (5800 psi)	T-ECOPUR NBR (70 Sh.A)
			-20 °C ... +100 °C	0,5 m/s	400 bar (5800 psi)	S-ECOPUR NBR (70 Sh.A)
			-30 °C ... +100 °C	0,5 m/s	400 bar (5800 psi)	G-ECOPUR NBR (70 Sh.A)
		<b>hydraulic, single acting</b> symmetric rod seal with support ring for simple applications to serve repair purpose, not recommended for new designs (profile S1 preferred). retainer ring in angled design possible.	-30 °C ... +100 °C	0,5 m/s	400 bar (5800 psi)	<b>Seal part</b> ECOPUR <b>Support ring</b>
			-20 °C ... +100 °C	0,5 m/s	400 bar (5800 psi)	H-ECOPUR
			-20 °C ... +100 °C	0,7 m/s	400 bar (5800 psi)	S-ECOPUR ECOTAL/
			-40 °C ... +100 °C	0,5 m/s	400 bar (5800 psi)	T-ECOPUR ECOMID*
			-30 °C ... +100 °C	0,5 m/s	400 bar (5800 psi)	G-ECOPUR
		<b>hydraulic, single acting</b> symmetric rod seal as S22, but more adaptation possibilities for diverse temperatures and media by selection of suitable seal material. retainer ring in angled design possible.	-30 °C ... +100 °C	0,5 m/s	160 bar (2300 psi)	<b>Seal part</b> ECORUBBER 1 ECOTAL
			-30 °C ... +100 °C	0,5 m/s	160 bar (2300 psi)	ECORUBBER 1 ECOMID
			-20 °C ... +200 °C	0,5 m/s	160 bar (2300 psi)	ECORUBBER 2 ECOFLON 2
			-50 °C ... +100 °C	0,5 m/s	160 bar (2300 psi)	ECORUBBER 3** ECOTAL
			-40 °C ... +100 °C	0,5 m/s	160 bar (2300 psi)	ECORUBBER 3** ECOMID
			-50 °C ... +150 °C	0,5 m/s	160 bar (2300 psi)	ECORUBBER 3** ECOFLON 2
			-25 °C ... +100 °C	0,5 m/s	160 bar (2300 psi)	ECORUBBER-H ECOTAL
			-25 °C ... +100 °C	0,5 m/s	160 bar (2300 psi)	ECORUBBER-H ECOMID
			-25 °C ... +150 °C	0,5 m/s	160 bar (2300 psi)	ECORUBBER-H ECOFLON 2
			-25 °C ... +150 °C	0,5 m/s	160 bar (2300 psi)	ECORUBBER-H
		<b>hydraulic, single acting</b> O-Ring activated rod seal with additional stabilizing lips and integrated active back ring for larger extrusion gaps, mainly used in mining industry.	-30 °C ... +100 °C	0,5 m/s	700 bar (10000 psi)	<b>Seal</b> ECOPUR <b>O-ring</b> <b>Back ring</b>
			-20 °C ... +100 °C	0,5 m/s	700 bar (10000 psi)	H-ECOPUR NBR (70 Sh.A)
			-30 °C ... +100 °C	0,5 m/s	700 bar (10000 psi)	T-ECOPUR NBR (70 Sh.A)
			-20 °C ... +100 °C	0,7 m/s	700 bar (10000 psi)	S-ECOPUR NBR (70 Sh.A)
			-30 °C ... +100 °C	0,5 m/s	700 bar (10000 psi)	G-ECOPUR NBR (70 Sh.A)
		<b>PTFE chevron set, single acting</b> optimized for low pressure, unequal angled chevron design results in good contact pressure even in low pressure range. external spring pretension necessary. mainly used in chemical, pharma and food industry.	-200 °C ... +260 °C	1,5 m/s	100 bar (1450 psi)	<b>S 25</b> <b>S 26</b> <b>S 27</b> ECO-FLON 2 ECOFLON 1 ECO-FLON 2
					<b>PTFE chevron set, single acting</b> optimized for high pressure, equal angled chevron design suitable for high pressure range. external spring pretension necessary. mainly used in chemical, pharma and food industry.	-200 °C ... +260 °C
		<b>hydraulic, single acting</b> chevron set, design with extremely flexible sealing lips for difficult operating conditions (bad guiding, large tolerance range). available as total chevron set as well as intermediate chevrons only (in case of metal male and female adaptors).				-30 °C ... +100 °C
			-20 °C ... +100 °C	0,5 m/s	500 bar (7200 psi)	H-ECOPUR
			-40 °C ... +100 °C	0,5 m/s	500 bar (7200 psi)	T-ECOPUR ECOTAL/
			-20 °C ... +100 °C	0,7 m/s	500 bar (7200 psi)	S-ECOPUR ECOMID*
			-30 °C ... +100 °C	0,5 m/s	500 bar (7200 psi)	G-ECOPUR
		<b>hydraulic, double acting</b> compact rod seal with almost no dead spots as required for applications in food and pharma industry, also commonly used as O-Ring replacement, because design with interference fit on outside diameter maintains non-twisting in dynamic applications.	-30 °C ... +110 °C	0,4 m/s	400 bar (5800 psi)	ECOPUR
			-20 °C ... +110 °C	0,4 m/s	400 bar (5800 psi)	H-ECOPUR
			-20 °C ... +110 °C	0,5 m/s	400 bar (5800 psi)	S-ECOPUR
			-50 °C ... +110 °C	0,4 m/s	400 bar (5800 psi)	T-ECOPUR
			-30 °C ... +110 °C	0,4 m/s	400 bar (5800 psi)	G-ECOPUR

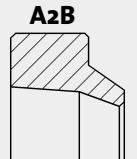

Not bolded symbols: please consult our technical dpmt. for application limitations

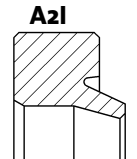
\* ECOTAL up to ø260 mm, ECOMID above ø260 mm  
\*\* attention: not suitable for mineral oils!



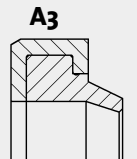

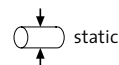
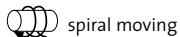
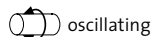
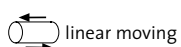





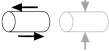





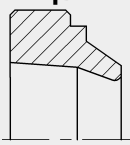



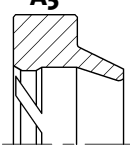

# Wipers

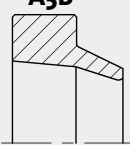
Application	Profile	Description	Temperature	max.speed	Material
  		<b>hydraulic, single acting</b> wiper with interference fit on outside diameter, providing a technically accurate closure at the cylinder. wiping edge assures a reliable protection against penetration of dust and dirt whilst allowing backflow of residual oil film. Back support area prevents tilting of wiper. For housings according ISO 6195-TypeA	-30 °C ... +110 °C	4 m/s	ECOPUR
			-20 °C ... +110 °C	4 m/s	H-ECOPUR
			-50 °C ... +110 °C	4 m/s	T-ECOPUR
			-20 °C ... +110 °C	5 m/s	S-ECOPUR
			-30 °C ... +110 °C	4 m/s	G-ECOPUR
			-30 °C ... +100 °C	4 m/s	ECORUBBER 1
			-25 °C ... +150 °C	4 m/s	ECORUBBER-H
			-20 °C ... +200 °C	4 m/s	ECORUBBER 2
-50 °C ... +150 °C	4 m/s	ECORUBBER 3**			
  		<b>hydraulic, single acting</b> as profile A01-A, but without back support area. for housings according ISO 6195-TypeA	-30 °C ... +110 °C	4 m/s	ECOPUR
			-20 °C ... +110 °C	4 m/s	H-ECOPUR
			-50 °C ... +110 °C	4 m/s	T-ECOPUR
			-20 °C ... +110 °C	5 m/s	S-ECOPUR
			-30 °C ... +110 °C	4 m/s	G-ECOPUR
			-30 °C ... +100 °C	4 m/s	ECORUBBER 1
			-25 °C ... +150 °C	4 m/s	ECORUBBER-H
			-20 °C ... +200 °C	4 m/s	ECORUBBER 2
-50 °C ... +150 °C	4 m/s	ECORUBBER 3**			
  		<b>hydraulic, single acting</b> wiper with interference fit on outside diameter. wiping edge assures a reliable protection against penetration of dust and dirt whilst allowing backflow of residual oil film. back support area prevents tilting of wiper.	-30 °C ... +110 °C	4 m/s	ECOPUR
			-20 °C ... +110 °C	4 m/s	H-ECOPUR
			-50 °C ... +110 °C	4 m/s	T-ECOPUR
			-20 °C ... +110 °C	5 m/s	S-ECOPUR
			-30 °C ... +110 °C	4 m/s	G-ECOPUR
			-30 °C ... +100 °C	4 m/s	ECORUBBER 1
			-25 °C ... +150 °C	4 m/s	ECORUBBER-H
			-20 °C ... +200 °C	4 m/s	ECORUBBER 2
-50 °C ... +150 °C	4 m/s	ECORUBBER 3**			
  		<b>hydraulic, single acting</b> wiper with interference fit on outside diameter. wiping edge assures a reliable protection against penetration of dust and dirt whilst allowing backflow of residual oil film.	-30 °C ... +110 °C	4 m/s	ECOPUR
			-20 °C ... +110 °C	4 m/s	H-ECOPUR
			-50 °C ... +110 °C	4 m/s	T-ECOPUR
			-20 °C ... +110 °C	5 m/s	S-ECOPUR
			-30 °C ... +110 °C	4 m/s	G-ECOPUR
			-30 °C ... +100 °C	4 m/s	ECORUBBER 1
			-25 °C ... +150 °C	4 m/s	ECORUBBER-H
			-20 °C ... +200 °C	4 m/s	ECORUBBER 2
-50 °C ... +150 °C	4 m/s	ECORUBBER 3**			
  		<b>hydraulic, single acting</b> as profile A2, but without back support area. special housing design according ISO 6195-TypeC	-30 °C ... +110 °C	4 m/s	ECOPUR
			-20 °C ... +110 °C	4 m/s	H-ECOPUR
			-50 °C ... +110 °C	4 m/s	T-ECOPUR
			-20 °C ... +110 °C	5 m/s	S-ECOPUR
			-30 °C ... +110 °C	4 m/s	G-ECOPUR
			-30 °C ... +100 °C	4 m/s	ECORUBBER 1
			-25 °C ... +150 °C	4 m/s	ECORUBBER-H
			-20 °C ... +200 °C	4 m/s	ECORUBBER 2
-50 °C ... +150 °C	4 m/s	ECORUBBER 3**			
  		<b>hydraulic, single acting</b> wiper with mounting cage for press-fit installation into axially open housings. wiping edge assures a reliable protection against penetration of dust and dirt, the use of plastic mounting cages avoids corrosion in the press-fit for housings according ISO 6195-TypeB	-30 °C ... +80 °C	4 m/s	ECOPUR
			-20 °C ... +80 °C	4 m/s	H-ECOPUR
			-40 °C ... +80 °C	4 m/s	T-ECOPUR
			-20 °C ... +80 °C	5 m/s	S-ECOPUR
			-30 °C ... +80 °C	4 m/s	G-ECOPUR
			-30 °C ... +80 °C	4 m/s	ECORUBBER 1
			-25 °C ... +80 °C	4 m/s	ECORUBBER-H
			-20 °C ... +200 °C	4 m/s	ECORUBBER 2
			-50 °C ... +150 °C	4 m/s	ECORUBBER 3**
					Housing

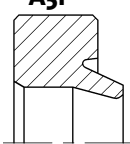

Not bolded symbols: please consult our technical dpmt. for application limitations

\* ECOTAL up to ø260 mm, ECOMID above ø260 mm  
 \*\* attention: not suitable for mineral oils !

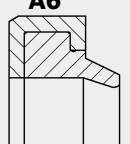











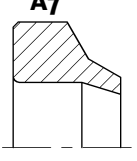



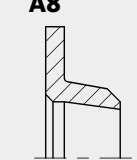



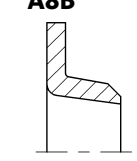



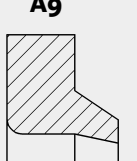



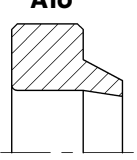

Application	Profile	Description	Temperature	max.speed	Material		
  		<b>pneumatic, single acting</b> wiper with interference fit on outside diameter, providing a technically accurate closure at the cylinder. special design of wiping lip allows retention of initial lubricating film. back support area prevents tilting of wiper. for housings according ISO 6195-TypeA	-30 °C ... +110 °C	4 m/s	ECOPUR		
			-20 °C ... +110 °C	4 m/s	H-ECOPUR		
			-50 °C ... +110 °C	4 m/s	T-ECOPUR		
			-20 °C ... +110 °C	5 m/s	S-ECOPUR		
			-30 °C ... +110 °C	4 m/s	G-ECOPUR		
			-30 °C ... +100 °C	4 m/s	ECORUBBER 1		
			-25 °C ... +150 °C	4 m/s	ECORUBBER-H		
			-20 °C ... +200 °C	4 m/s	ECORUBBER 2		
			-50 °C ... +150 °C	4 m/s	ECORUBBER 3**		
			  		<b>pneumatic, single acting</b> as profile A4, but without back support area for housings according ISO 6195-TypeA		-30 °C ... +110 °C
-20 °C ... +110 °C	4 m/s	H-ECOPUR					
-50 °C ... +110 °C	4 m/s	T-ECOPUR					
-20 °C ... +110 °C	5 m/s	S-ECOPUR					
-30 °C ... +110 °C	4 m/s	G-ECOPUR					
-30 °C ... +100 °C	4 m/s	ECORUBBER 1					
-25 °C ... +150 °C	4 m/s	ECORUBBER-H					
-20 °C ... +200 °C	4 m/s	ECORUBBER 2					
-50 °C ... +150 °C	4 m/s	ECORUBBER 3**					
  		<b>pneumatic, single acting</b> wiper with interference fit on outside diameter. special design of wiping lip allows retention of initial lubricating film. back support area prevents tilting of wiper.				-30 °C ... +110 °C	4 m/s
			-20 °C ... +110 °C	4 m/s	H-ECOPUR		
			-50 °C ... +110 °C	4 m/s	T-ECOPUR		
			-20 °C ... +110 °C	5 m/s	S-ECOPUR		
			-30 °C ... +110 °C	4 m/s	G-ECOPUR		
			-30 °C ... +100 °C	4 m/s	ECORUBBER 1		
			-25 °C ... +150 °C	4 m/s	ECORUBBER-H		
			-20 °C ... +200 °C	4 m/s	ECORUBBER 2		
			-50 °C ... +150 °C	4 m/s	ECORUBBER 3**		
			  		<b>pneumatic, single acting</b> wiper with interference fit on outside diameter. special design of wiping lip allows retention of initial lubricating film.	-30 °C ... +110 °C	4 m/s
-20 °C ... +110 °C	4 m/s	H-ECOPUR					
-50 °C ... +110 °C	4 m/s	T-ECOPUR					
-20 °C ... +110 °C	5 m/s	S-ECOPUR					
-30 °C ... +110 °C	4 m/s	G-ECOPUR					
-30 °C ... +100 °C	4 m/s	ECORUBBER 1					
-25 °C ... +150 °C	4 m/s	ECORUBBER-H					
-20 °C ... +200 °C	4 m/s	ECORUBBER 2					
-50 °C ... +150 °C	4 m/s	ECORUBBER 3**					
  		<b>pneumatic, single acting</b> as profile A5, but without back support area. special housing design according ISO 6195-TypeC				-30 °C ... +110 °C	4 m/s
			-20 °C ... +110 °C	4 m/s	H-ECOPUR		
			-50 °C ... +110 °C	4 m/s	T-ECOPUR		
			-20 °C ... +110 °C	5 m/s	S-ECOPUR		
			-30 °C ... +110 °C	4 m/s	G-ECOPUR		
			-30 °C ... +100 °C	4 m/s	ECORUBBER 1		
			-25 °C ... +150 °C	4 m/s	ECORUBBER-H		
			-20 °C ... +200 °C	4 m/s	ECORUBBER 2		
			-50 °C ... +150 °C	4 m/s	ECORUBBER 3**		
			  		<b>pneumatic, single acting</b> wiper with mounting cage for press-fit installation into axially open housings. special design of wiping lip allows retention of initial lubricating film, the use of plastic mounting cages avoids corrosion at the press-fit. for housings according ISO 6195-TypeB	-30 °C ... +80 °C	4 m/s
-20 °C ... +80 °C	4 m/s	H-ECOPUR					
-40 °C ... +80 °C	4 m/s	T-ECOPUR				ECOTAL/ ECOMID*	
-20 °C ... +80 °C	5 m/s	S-ECOPUR					
-30 °C ... +80 °C	4 m/s	G-ECOPUR					
-30 °C ... +80 °C	4 m/s	ECORUBBER 1					
-25 °C ... +80 °C	4 m/s	ECORUBBER-H					
-20 °C ... +200 °C	4 m/s	ECORUBBER 2					
-50 °C ... +150 °C	4 m/s	ECORUBBER 3**					
-30 °C ... +80 °C	4 m/s	ECOPUR					ECOPAЕК
-20 °C ... +80 °C	4 m/s	H-ECOPUR					
-40 °C ... +80 °C	4 m/s	T-ECOPUR					ECOTAL/ ECOMID*
-20 °C ... +80 °C	5 m/s	S-ECOPUR					
-30 °C ... +80 °C	4 m/s	G-ECOPUR	ECOTAL/ ECOMID*				
-30 °C ... +80 °C	4 m/s	ECORUBBER 1					
-25 °C ... +80 °C	4 m/s	ECORUBBER-H	ECOTAL/ ECOMID*				
-20 °C ... +200 °C	4 m/s	ECORUBBER 2					
-50 °C ... +150 °C	4 m/s	ECORUBBER 3**	ECOPAЕК				

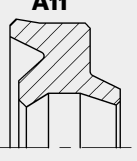

Not bolded symbols: please consult our technical dpmt. for application limitations

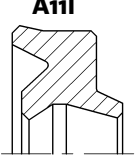
\* ECOTAL up to ø260 mm, ECOMID above ø260 mm



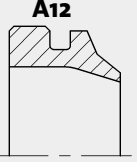

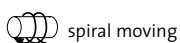
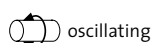
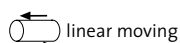







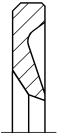

\*\* attention: not suitable for mineral oils !

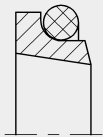
Application	Profile	Description	Temperature	max.speed	Material
  	 <b>A7</b>	<b>hydraulic, single acting</b> wiper to fit in angled housings (30° angle). design mainly used in british equipment, in inch as well as metric dimensions.	-30 °C ... +110 °C	4 m/s	ECOPUR
			-20 °C ... +110 °C	4 m/s	H-ECOPUR
			-50 °C ... +110 °C	4 m/s	T-ECOPUR
			-20 °C ... +110 °C	5 m/s	S-ECOPUR
			-30 °C ... +110 °C	4 m/s	G-ECOPUR
			-30 °C ... +100 °C	4 m/s	ECORUBBER 1
			-25 °C ... +150 °C	4 m/s	ECORUBBER-H
			-20 °C ... +200 °C	4 m/s	ECORUBBER 2
-50 °C ... +150 °C	4 m/s	ECORUBBER 3**			
  	 <b>A8</b>	<b>hydraulic/pneumatic, single acting</b> wiper usually fixed in housing with clamp flange. mainly used for replacement in old hydraulic and pneumatic cylinders or for secondary applications.	-30 °C ... +110 °C	4 m/s	ECOPUR
			-20 °C ... +110 °C	4 m/s	H-ECOPUR
			-50 °C ... +110 °C	4 m/s	T-ECOPUR
			-20 °C ... +110 °C	5 m/s	S-ECOPUR
			-30 °C ... +110 °C	4 m/s	G-ECOPUR
			-30 °C ... +100 °C	4 m/s	ECORUBBER 1
			-25 °C ... +150 °C	4 m/s	ECORUBBER-H
			-20 °C ... +200 °C	4 m/s	ECORUBBER 2
-50 °C ... +150 °C	4 m/s	ECORUBBER 3**			
  	 <b>A8B</b>	<b>hydraulic/pneumatic, single acting</b> wiper usually fixed in housing with clamp flange. mainly used for replacement in old hydraulic and pneumatic cylinders or for secondary applications.	-30 °C ... +110 °C	4 m/s	ECOPUR
			-20 °C ... +110 °C	4 m/s	H-ECOPUR
			-50 °C ... +110 °C	4 m/s	T-ECOPUR
			-20 °C ... +110 °C	5 m/s	S-ECOPUR
			-30 °C ... +110 °C	4 m/s	G-ECOPUR
			-30 °C ... +100 °C	4 m/s	ECORUBBER 1
			-25 °C ... +150 °C	4 m/s	ECORUBBER-H
			-20 °C ... +200 °C	4 m/s	ECORUBBER 2
-50 °C ... +150 °C	4 m/s	ECORUBBER 3**			
  	 <b>A9</b>	<b>hydraulic, single acting</b> wiper with dimensioning according to common types used in USA. for housings according AN 6231, ANSI/B93.35	-30 °C ... +110 °C	4 m/s	ECOPUR
			-20 °C ... +110 °C	4 m/s	H-ECOPUR
			-50 °C ... +110 °C	4 m/s	T-ECOPUR
			-20 °C ... +110 °C	5 m/s	S-ECOPUR
			-30 °C ... +110 °C	4 m/s	G-ECOPUR
			-30 °C ... +100 °C	4 m/s	ECORUBBER 1
			-25 °C ... +150 °C	4 m/s	ECORUBBER-H
			-20 °C ... +200 °C	4 m/s	ECORUBBER 2
-50 °C ... +150 °C	4 m/s	ECORUBBER 3**			
  	 <b>A10</b>	<b>hydraulic, single acting</b> wiper with dimensioning according to common types used in USA. fixed relation between cross-section and height of wiper. for housings according AN 6231, ANSI/B93.35	-30 °C ... +110 °C	4 m/s	ECOPUR
			-20 °C ... +110 °C	4 m/s	H-ECOPUR
			-50 °C ... +110 °C	4 m/s	T-ECOPUR
			-20 °C ... +110 °C	5 m/s	S-ECOPUR
			-30 °C ... +110 °C	4 m/s	G-ECOPUR
			-30 °C ... +100 °C	4 m/s	ECORUBBER 1
			-25 °C ... +150 °C	4 m/s	ECORUBBER-H
			-20 °C ... +200 °C	4 m/s	ECORUBBER 2
-50 °C ... +150 °C	4 m/s	ECORUBBER 3**			
  	 <b>A11</b>	<b>hydraulic/pneumatic, double acting</b> wiper including additional sealing lip. used in combination with O-ring activated PTFE seals (tandem) to reduce residual oil film. also used as complete solution for pneumatic applications in small diameter range. max. allowed pressure load: 16 bar (230 psi)	-30 °C ... +110 °C	4 m/s	ECOPUR
			-20 °C ... +110 °C	4 m/s	H-ECOPUR
			-50 °C ... +110 °C	4 m/s	T-ECOPUR
			-20 °C ... +110 °C	5 m/s	S-ECOPUR
			-30 °C ... +110 °C	4 m/s	G-ECOPUR
			-30 °C ... +100 °C	4 m/s	ECORUBBER 1
			-25 °C ... +150 °C	4 m/s	ECORUBBER-H
			-20 °C ... +200 °C	4 m/s	ECORUBBER 2
-50 °C ... +150 °C	4 m/s	ECORUBBER 3**			
  	 <b>A11l</b>	<b>hydraulic/pneumatic, double acting</b> as profile A11, special housing design according ISO 6195-TypeC	-30 °C ... +110 °C	4 m/s	ECOPUR
			-20 °C ... +110 °C	4 m/s	H-ECOPUR
			-50 °C ... +110 °C	4 m/s	T-ECOPUR
			-20 °C ... +110 °C	5 m/s	S-ECOPUR
			-30 °C ... +110 °C	4 m/s	G-ECOPUR
			-30 °C ... +100 °C	4 m/s	ECORUBBER 1
			-25 °C ... +150 °C	4 m/s	ECORUBBER-H
			-20 °C ... +200 °C	4 m/s	ECORUBBER 2
-50 °C ... +150 °C	4 m/s	ECORUBBER 3**			
  	 <b>A12</b>	<b>hydraulic, single acting</b> wiper with secondary lip, the technically accurate closure at the cylinder is providing reliable protection, even for heavy contamination.	-30 °C ... +110 °C	4 m/s	ECOPUR
			-20 °C ... +110 °C	4 m/s	H-ECOPUR
			-50 °C ... +110 °C	4 m/s	T-ECOPUR
			-20 °C ... +110 °C	5 m/s	S-ECOPUR
			-30 °C ... +110 °C	4 m/s	G-ECOPUR

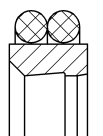

Not bolded symbols: please consult our technical dpmt. for application limitations

\* ECOTAL up to ø260 mm, ECOMID above ø260 mm  
\*\* attention: not suitable for mineral oils !

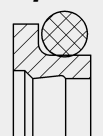
Application	Profile	Description	Temperature	max.speed	max.Pressure	Material	
  	<b>A13</b> 	<b>hydraulic/pneumatic, single acting</b> scraper ring, mainly used in combination with wiper A2 or A1. firmly clinging dirt and extremely heavy soiling (mud, tar, ice) is wiped off, following elastomeric wiper is protected from damage. recommended materials provide good dry running properties, high stiffness and breaking strenght.	-50 °C ... +80 °C	1 m/s	-	ECOTAL	
			-40 °C ... +80 °C	1 m/s	-	ECOMID*	
			-50 °C ... +260 °C	1 m/s	-	ECOPAЕК	
  	<b>A25</b> 	<b>hydraulic/pneumatic, single acting</b> PTFE-wiper with O-ring as preloading element. PTFE part takes over wiping function, O-ring maintains equal contact pressure. good dry running properties, no "stick-slip". excellent chemical and thermal resistance (depends on O-ring).	-30 °C ... +100 °C	10 m/s	-	ECOFLON 2	<b>Glide ring</b> Energiizer NBR (70Sh.A)
			-20 °C ... +200 °C	10 m/s	-	ECOFLON 2	FPM (75Sh.A)
			-30 °C ... +100 °C	10 m/s	-	ECOFLON 3	NBR (70Sh.A)
			-20 °C ... +200 °C	10 m/s	-	ECOFLON 3	FPM (75Sh.A)
			-30 °C ... +100 °C	10 m/s	-	ECOFLON 4	NBR (70Sh.A)
			-20 °C ... +200 °C	10 m/s	-	ECOFLON 4	FPM (75Sh.A)
  	<b>A26</b> 	<b>hydraulic/pneumatic, double acting</b> PTFE-double wiper with two O-rings as preloading elements. wiping edge assures a reliable protection against penetration of dust and dirt. additional sealing lip for reduction of residual oil film if used in combination with O-ring activated PTFE seals type Sg (tandem). excellent chemical and thermal resistance (depends on O-ring).	-30 °C ... +100 °C	10 m/s	16 bar (230 psi)	ECOFLON 2	<b>Glide ring</b> Energiizer NBR (70Sh.A)
			-20 °C ... +200 °C	10 m/s	16 bar (230 psi)	ECOFLON 2	FPM (75Sh.A)
			-30 °C ... +100 °C	10 m/s	16 bar (230 psi)	ECOFLON 3	NBR (70Sh.A)
			-20 °C ... +200 °C	10 m/s	16 bar (230 psi)	ECOFLON 3	FPM (75Sh.A)
			-30 °C ... +100 °C	10 m/s	16 bar (230 psi)	ECOFLON 4	NBR (70Sh.A)
			-20 °C ... +200 °C	10 m/s	16 bar (230 psi)	ECOFLON 4	FPM (75Sh.A)
  	<b>A27</b> 	<b>hydraulic/pneumatic, double acting</b> PTFE-double wiper with O-ring as preloading element. wiping edge assures a reliable protection against penetration of dust and dirt. additional sealing lip for reduction of residual oil film if used in combination with O-ring activated PTFE seals type Sg (tandem). excellent chemical and thermal resistance (depends on O-ring).	-30 °C ... +100 °C	10 m/s	16 bar (230 psi)	ECOFLON 2	<b>Glide ring</b> Energiizer NBR (70Sh.A)
			-20 °C ... +200 °C	10 m/s	16 bar (230 psi)	ECOFLON 2	FPM (75Sh.A)
			-30 °C ... +100 °C	10 m/s	16 bar (230 psi)	ECOFLON 3	NBR (70Sh.A)
			-20 °C ... +200 °C	10 m/s	16 bar (230 psi)	ECOFLON 3	FPM (75Sh.A)
			-30 °C ... +100 °C	10 m/s	16 bar (230 psi)	ECOFLON 4	NBR (70Sh.A)
			-20 °C ... +200 °C	10 m/s	16 bar (230 psi)	ECOFLON 4	FPM (75Sh.A)

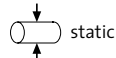
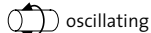
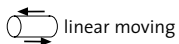









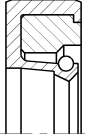

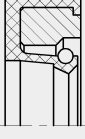
Not bolded symbols: please consult our technical dpmt. for application limitations

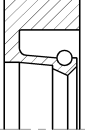
\* ECOTAL up to ø260 mm, ECOMID above ø260 mm

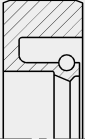
\*\* attention: not suitable for mineral oils !

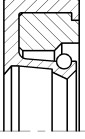

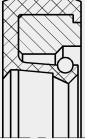

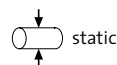
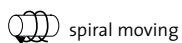
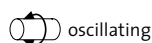
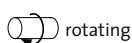
# Rotary seals

Application	Profile	Description	Temperature	max.speed	max. Pressure	Material	
	<b>R1</b> 	<b>single acting rotary shaft seal</b> spring loaded lip seal with retainer ring for press-fit installation into axially open housings. wide range of applications in every sector of industry, mainly as protecting element for bearings.	-30 °C ... +80 °C	5 m/s	0,5 bar (7 psi)	<b>Seal part</b> ECOPUR	<b>Energizer</b>  ECOTAL/ ECOMID*
			-20 °C ... +80 °C	5 m/s	0,5 bar (7 psi)	H-ECOPUR	
			-40 °C ... +80 °C	5 m/s	0,5 bar (7 psi)	T-ECOPUR	
			-20 °C ... +80 °C	6 m/s	0,5 bar (7 psi)	S-ECOPUR	
			-30 °C ... +80 °C	5 m/s	0,5 bar (7 psi)	G-ECOPUR	
	<b>R1R</b> 	<b>single acting rotary shaft seal</b> spring loaded lip seal with retainer ring for press-fit installation into axially open housings. good adaptation possibilities for diverse temperatures and media by selection of suitable seal material. wide range of applications in every sector of industry, mainly as protecting element for bearings.	-30 °C ... +80 °C	10 m/s	0,5 bar (7 psi)	<b>Seal part</b> ECORUBBER 1	<b>Energizer</b>  ECOTAL/ ECOMID*
			-25 °C ... +80 °C	10 m/s	0,5 bar (7 psi)	ECORUBBER-H	
			-20 °C ... +200 °C	15 m/s	0,5 bar (7 psi)	ECORUBBER 2	
			-50 °C ... +80 °C	10 m/s	0,5 bar (7 psi)	ECORUBBER 3**	
			-50 °C ... +150 °C	10 m/s	0,5 bar (7 psi)	ECORUBBER 3**	
			-50 °C ... +80 °C	5 m/s	0,2 bar (3 psi)	ECOSIL	
			-60 °C ... +200 °C	5 m/s	0,2 bar (3 psi)	ECOSIL	
	<b>R1AF</b> 	<b>single acting rotary shaft seal</b> spring loaded lip seal with solid outer section for axially open housings with clamping plate fixation. mainly used for rolling mills, large gear mechanisms in heavy duty machinery, for shipbuilding industry and civil engineering.	-30 °C ... +110 °C	5 m/s	0,5 bar (7 psi)	ECOPUR	
			-20 °C ... +110 °C	5 m/s	0,5 bar (7 psi)	H-ECOPUR	
			-50 °C ... +110 °C	5 m/s	0,5 bar (7 psi)	T-ECOPUR	
			-20 °C ... +110 °C	6 m/s	0,5 bar (7 psi)	S-ECOPUR	
			-30 °C ... +100 °C	5 m/s	0,5 bar (7 psi)	G-ECOPUR	
			-30 °C ... +100 °C	10 m/s	0,5 bar (7 psi)	ECORUBBER 1	
			-25 °C ... +150 °C	10 m/s	0,5 bar (7 psi)	ECORUBBER-H	
			-20 °C ... +200 °C	15 m/s	0,5 bar (7 psi)	ECORUBBER 2	
			-50 °C ... +150 °C	10 m/s	0,2 bar (3 psi)	ECORUBBER 3**	
			-60 °C ... +200 °C	5 m/s	0,2 bar (3 psi)	ECOSIL	
				<b>R1AS</b> 	<b>single acting rotary shaft seal</b> split version of a spring loaded lip seal with solid outer section for axially open housings with clamping plate fixation. mainly used for repair purpose on rolling mills, large gear mechanisms in heavy duty machinery, for shipbuilding industry and civil engineering.	-30 °C ... +110 °C	
-20 °C ... +110 °C	5 m/s	0,5 bar (7 psi)				H-ECOPUR	
-50 °C ... +110 °C	5 m/s	0,5 bar (7 psi)				T-ECOPUR	
-20 °C ... +110 °C	6 m/s	0,5 bar (7 psi)				S-ECOPUR	
-30 °C ... +100 °C	5 m/s	0,5 bar (7 psi)				G-ECOPUR	
-30 °C ... +100 °C	10 m/s	0,5 bar (7 psi)				ECORUBBER 1	
-25 °C ... +150 °C	10 m/s	0,5 bar (7 psi)				ECORUBBER-H	
-20 °C ... +200 °C	15 m/s	0,5 bar (7 psi)				ECORUBBER 2	
-50 °C ... +150 °C	10 m/s	0,2 bar (3 psi)				ECORUBBER 3**	
-60 °C ... +200 °C	5 m/s	0,2 bar (3 psi)				ECOSIL	
	<b>R2</b> 	<b>single acting rotary shaft seal</b> as profile R1, but with additional dust lip to avoid ingress of dust and dirt.				-30 °C ... +80 °C	5 m/s
			-20 °C ... +80 °C	5 m/s	0,5 bar (7 psi)	H-ECOPUR	
			-40 °C ... +80 °C	5 m/s	0,5 bar (7 psi)	T-ECOPUR	
			-20 °C ... +80 °C	6 m/s	0,5 bar (7 psi)	S-ECOPUR	
			-30 °C ... +80 °C	5 m/s	0,5 bar (7 psi)	G-ECOPUR	
	<b>R2R</b> 	<b>single acting rotary shaft seal</b> as profile R1R, but with additional dust lip to avoid ingress of dust and dirt.	-30 °C ... +80 °C	10 m/s	0,5 bar (7 psi)	<b>Seal part</b> ECORUBBER 1	<b>Energizer</b>  ECOTAL/ ECOMID*
			-25 °C ... +80 °C	10 m/s	0,5 bar (7 psi)	ECORUBBER-H	
			-20 °C ... +200 °C	15 m/s	0,5 bar (7 psi)	ECORUBBER 2	
			-50 °C ... +80 °C	10 m/s	0,5 bar (7 psi)	ECORUBBER 3**	
			-50 °C ... +150 °C	10 m/s	0,5 bar (7 psi)	ECORUBBER 3**	
			-50 °C ... +80 °C	5 m/s	0,2 bar (3 psi)	ECOSIL	
			-60 °C ... +200 °C	5 m/s	0,2 bar (3 psi)	ECOSIL	

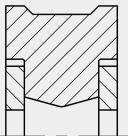
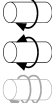
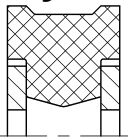

Not bolded symbols: please consult our technical dpmt. for application limitations

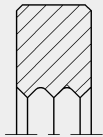
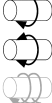
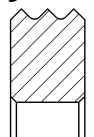
\* ECOTAL up to ø260 mm, ECOMID above ø260 mm  
 \*\* attention: not suitable for mineral oils!

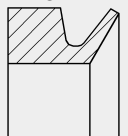
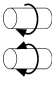
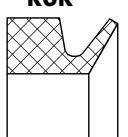

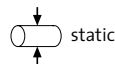
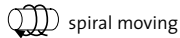
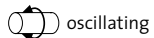
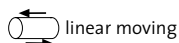





Application	Profile	Description	Temperature	max.speed	max. Pressure	Material	
	<b>R3</b> 	<b>double acting rotary seal</b> rotary seal with integrated backup rings for pivoting motion in hydraulic systems. interference fit on outside diameter maintains stable fit in the housing, backup rings permit larger extrusion gap / higher pressure. mainly used for rotary pivots on excavators, grabs	-30 °C ... +100 °C	0,2 m/s	400 bar (5800 psi)	ECOPUR	<b>Seal part</b>
			-20 °C ... +100 °C	0,2 m/s	400 bar (5800 psi)	H-ECOPUR	<b>Back ring</b>
			-40 °C ... +100 °C	0,2 m/s	400 bar (5800 psi)	T-ECOPUR	
			-20 °C ... +100 °C	0,3 m/s	400 bar (5800 psi)	S-ECOPUR	
			-30 °C ... +100 °C	0,2 m/s	400 bar (5800 psi)	G-ECOPUR	
	<b>R3R</b> 	<b>double acting rotary seal</b> as profile R3 but more adaptation possibilities for diverse temperatures and media by selection of suitable seal material.	-30 °C ... +100 °C	0,2 m/s	250 bar (3600 psi)	ECORUBBER 1	<b>Seal part</b>
			-30 °C ... +100 °C	0,2 m/s	250 bar (3600 psi)	ECORUBBER 1	<b>Back rings</b>
			-25 °C ... +100 °C	0,2 m/s	250 bar (3600 psi)	ECORUBBER-H	
			-25 °C ... +100 °C	0,2 m/s	250 bar (3600 psi)	ECORUBBER-H	
			-20 °C ... +200 °C	0,2 m/s	250 bar (3600 psi)	ECORUBBER 2	
	<b>R4</b> 	<b>double acting rotary seal</b> space saving rotary seal for pivoting motion in hydraulic systems. interference fit on outside diameter maintains stable fit in the housing, dynamic sealing lips on inside diameter.	-30 °C ... +110 °C	0,2 m/s	160 bar (2300 psi)	ECOPUR	
			-20 °C ... +110 °C	0,2 m/s	160 bar (2300 psi)	H-ECOPUR	
			-50 °C ... +110 °C	0,2 m/s	160 bar (2300 psi)	T-ECOPUR	
			-20 °C ... +110 °C	0,3 m/s	160 bar (2300 psi)	S-ECOPUR	
			-30 °C ... +110 °C	0,2 m/s	160 bar (2300 psi)	G-ECOPUR	
			-30 °C ... +100 °C	0,2 m/s	100 bar (1450 psi)	ECORUBBER 1	
			-25 °C ... +150 °C	0,2 m/s	100 bar (1450 psi)	ECORUBBER-H	
			-20 °C ... +200 °C	0,2 m/s	100 bar (1450 psi)	ECORUBBER 2	
			-50 °C ... +150 °C	0,2 m/s	100 bar (1450 psi)	ECORUBBER 3**	
	<b>R5</b> 	<b>double acting rotary seal</b> space saving rotary seal for pivoting motion in hydraulic systems. interference fit on inside diameter maintains stable fit in the housing, dynamic sealing lips on outside diameter.	-30 °C ... +110 °C	0,2 m/s	160 bar (2300 psi)	ECOPUR	
			-20 °C ... +110 °C	0,2 m/s	160 bar (2300 psi)	H-ECOPUR	
			-50 °C ... +110 °C	0,2 m/s	160 bar (2300 psi)	T-ECOPUR	
			-20 °C ... +110 °C	0,3 m/s	160 bar (2300 psi)	S-ECOPUR	
			-30 °C ... +110 °C	0,2 m/s	160 bar (2300 psi)	G-ECOPUR	
			-30 °C ... +100 °C	0,2 m/s	100 bar (1450 psi)	ECORUBBER 1	
			-25 °C ... +150 °C	0,2 m/s	100 bar (1450 psi)	ECORUBBER-H	
			-20 °C ... +200 °C	0,2 m/s	100 bar (1450 psi)	ECORUBBER 2	
			-50 °C ... +150 °C	0,2 m/s	100 bar (1450 psi)	ECORUBBER 3**	
	<b>R6</b> 	<b>axially acting rotary seal</b> elastic, excellent wear resistant V-Ring with interference fit on the shaft, rotates with the shaft, sealing axially against shaft collars, thrust blocks or the outer race of roller bearings, protecting the bearing against dust, dirt, oil splash, watersplash and similar media. acting as a seal and slinger ring.	-30 °C ... +110 °C	25 m/s	-	ECOPUR	
			-20 °C ... +110 °C	25 m/s	-	H-ECOPUR	
			-50 °C ... +110 °C	25 m/s	-	T-ECOPUR	
			-20 °C ... +110 °C	25 m/s	-	S-ECOPUR	
			-30 °C ... +110 °C	25 m/s	-	G-ECOPUR	
	<b>R6R</b> 	<b>axially acting rotary seal</b> elastic, good wear resistant V-Ring as profile R6, but more adaptation possibilities for diverse temperatures and media by selection of suitable seal material.	-30 °C ... +100 °C	25 m/s	-	ECORUBBER 1	
			-20 °C ... +200 °C	25 m/s	-	ECORUBBER 2	
			-50 °C ... +150 °C	25 m/s	-	ECORUBBER 3**	
			-25 °C ... +150 °C	25 m/s	-	ECORUBBER-H	

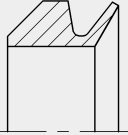

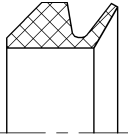
Not bolded symbols: please consult our technical dpmt. for application limitations

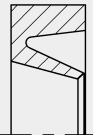
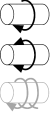
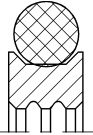
\* ECOTAL up to ø260 mm, ECOMID above ø260 mm

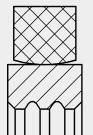
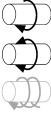
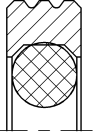
\*\* attention: not suitable for mineral oils !

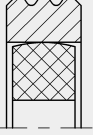

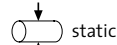
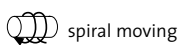
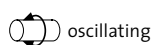
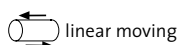







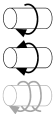
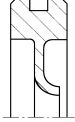

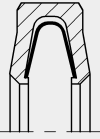
Application	Profile	Description	Temperature	max.speed	max. Pressure	Material	
	<b>R7</b> 	<b>axially acting rotary seal</b> elastic, excellent wear resistant V-Ring with interference fit on the shaft, rotates with the shaft, sealing axially against shaft collars, thrust blocks or the outer race of roller bearings, protecting the bearing against dust, dirt, oil splash, watersplash and similar media. acting as a seal- and slingerring.	-30 °C ... +110 °C	25 m/s	-	ECOPUR	
			-20 °C ... +110 °C	25 m/s	-	H-ECOPUR	
			-50 °C ... +110 °C	25 m/s	-	T-ECOPUR	
			-20 °C ... +110 °C	25 m/s	-	S-ECOPUR	
			-30 °C ... +110 °C	25 m/s	-	G-ECOPUR	
	<b>R7R</b> 	<b>axially acting rotary seal</b> elastic, good wear resistant V-Ring as profile R7, but more adaptation possibilities for diverse temperatures and media by selection of suitable seal material.	-30 °C ... +100 °C	25 m/s	-	ECORUBBER 1	
			-20 °C ... +200 °C	25 m/s	-	ECORUBBER 2	
			-50 °C ... +150 °C	25 m/s	-	ECORUBBER 3**	
			-25 °C ... +150 °C	25 m/s	-	ECORUBBER-H	
	<b>R8</b> 	<b>single acting rotary seal</b> springless rotary lip seal with arbitrary preload on inside and outside diameter in order to design the seal to different specific needs.	upon application	upon application	upon application	all materials possible	
	<b>R9F</b> 	<b>double acting rotary seal</b> O-ring activated, low friction PTFE rotary seal. mainly used in applications with alternating pressure from one side of the seal to the other, such as hose reels, swivel joints, rotating track rings and machine tool hydraulics. good chemical and thermal resistance achievable by selection of suitable O-Ring material.	-30 °C ... +100 °C	0,4 m/s	350 bar (5000 psi)	<a href="#">Glide ring</a> ECOFLON 2,3,4	<a href="#">Energizer</a> NBR (70Sh.A) ECORUBBER 1
			-30 °C ... +100 °C	0,4 m/s	350 bar (5000 psi)	ECOFLON 2,3,4	
			-30 °C ... +80 °C	0,4 m/s	350 bar (5000 psi)	ECOPE	
	<b>R9FS</b> 	<b>double acting rotary seal</b> as profile R9F, but with a profile ring energizer instead of the O-ring. For heavy duty applications and non standard housings.	-30 °C ... +100 °C	0,4 m/s	350 bar (5000 psi)	<a href="#">Glide ring</a> ECOFLON 2,3,4	<a href="#">Energizer</a> NBR (70Sh.A) ECORUBBER 1
			-30 °C ... +100 °C	0,4 m/s	350 bar (5000 psi)	ECOFLON 2,3,4	
			-30 °C ... +80 °C	0,4 m/s	350 bar (5000 psi)	ECOPE	
	<b>R10F</b> 	<b>double acting rotary seal</b> O-ring activated, low friction PTFE rotary seal. mainly used in applications with alternating pressure from one side of the seal to the other, such as hose reels, swivel joints, rotating track rings and machine tool hydraulics. good chemical and thermal resistance achievable by selection of suitable O-Ring material.	-30 °C ... +100 °C	0,4 m/s	350 bar (5000 psi)	<a href="#">Glide ring</a> ECOFLON 2,3,4	<a href="#">Energizer</a> NBR (70Sh.A) ECORUBBER 1
			-30 °C ... +100 °C	0,4 m/s	350 bar (5000 psi)	ECOFLON 2,3,4	
			-30 °C ... +80 °C	0,4 m/s	350 bar (5000 psi)	ECOPE	
	<b>R10FS</b> 	<b>double acting rotary seal</b> as profile R10F, but with a profile ring energizer instead of the O-ring. For heavy duty applications and non standard housings.	-30 °C ... +100 °C	0,4 m/s	350 bar (5000 psi)	<a href="#">Glide ring</a> ECOFLON 2,3,4	<a href="#">Energizer</a> NBR (70Sh.A) ECORUBBER 1
			-30 °C ... +100 °C	0,4 m/s	350 bar (5000 psi)	ECOFLON 2,3,4	
			-30 °C ... +80 °C	0,4 m/s	350 bar (5000 psi)	ECOPE	

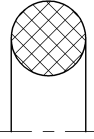

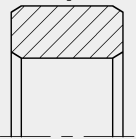
Not bolded symbols: please consult our technical dpmt. for application limitations

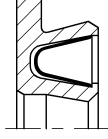
\* ECOTAL up to ø260 mm, ECOMID above ø260 mm

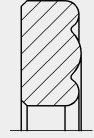
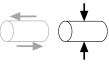
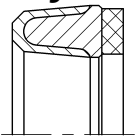
\*\* attention: not suitable for mineral oils !

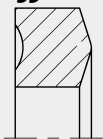
Application	Profile	Description	Temperature	max.speed	max. Pressure	Material
	<b>R11F</b> 	<b>single acting PTFE rotary seal</b> space saving rotary seal, deformed sealing lip acts selfadjusting on increasing temperature. for axially open housings with clamping plate fixation, elastic secondary seal or integrated O-ring necessary for static sealing in the housing. excellent chemical and thermal resistance, suitable for high speed applications.	-200°C ... +260°C	20 m/s	5 bar (70 psi)	ECOFLON 2,3,4
	<b>R12F</b> 	<b>single acting PTFE flange seal</b> fingerspring activated flange seal, excellent chemical and thermal resistance, mainly used on flanges, fittings or pivoting joints in chemical industry.	-200°C ... +260°C	15 m/s	300 bar (4300 psi)	Seal ECOFLON 2,3,4 Spring 1.4310
	<b>R13</b> 	<b>O-Ring</b> well known, simple O-Ring with proven reliability in multiple applications in every sector of industry. excellent adaptation possibilities for diverse temperatures and media by selection of suitable seal material. mainly used as static seal or as preloading element for PTFE-seals. for most dynamic applications we recommend to prefer profiles like S20/K20 or S35/K35.	-30 °C ... +110 °C -20 °C ... +110 °C -50 °C ... +110 °C -20 °C ... +110 °C -30 °C ... +110 °C -30 °C ... +100 °C -20 °C ... +200°C -50 °C ... +50 °C -25 °C ... +150 °C -200°C .. +260°C	- - - - - - - - - -	600 bar (8700 psi) 600 bar (8700 psi) 600 bar (8700 psi) 600 bar (8700 psi) 600 bar (8700 psi) 160 bar (2300 psi) 160 bar (2300 psi) 160 bar (2300 psi) 160 bar (2300 psi) 160 bar (2300 psi)	ECOPUR H-ECOPUR T-ECOPUR S-ECOPUR G-ECOPUR ECORUBBER 1 ECORUBBER 2 ECORUBBER 3** ECORUBBER-H ECOFLON 1
	<b>R14</b> 	<b>Square ring</b> well known, simple square ring, mainly used for static applications or as gaskets. excellent adaptation possibilities for diverse temperatures and media by selection of suitable seal material.	upon application	upon application	upon application	all materials possible
	<b>R19F</b> 	<b>single acting PTFE rotary seal</b> fingerspring activated PTFE seal with integrated clamping flange on the back of seal for clamping fixation, acting as anti-twist device. excellent chemical and thermal resistance. suitable for relatively high pressure and high speed, however, allowable pressure and speed depend on each other, it is not recommended to use all maximum values simultaneously.	-200 °C ... +260 °C upon application	2 m/s upon application	150 bar (2100 psi) upon application	Seal ECOFLON 2,3,4 all other materials possible Spring 1.4310 1.4310
	<b>R20</b> 	<b>single acting flange seal</b> flange seal for static applications, suitable for high pressure range. direction of pressurization (from inside or outside) must be indicated when ordering the seal.	-30 °C ... +110 °C -20 °C ... +110 °C -50 °C ... +110 °C -20 °C ... +110 °C -30 °C ... +110 °C	- - - - -	800 bar (11600 psi) 800 bar (11600 psi) 800 bar (11600 psi) 800 bar (11600 psi) 800 bar (11600 psi)	ECOPUR H-ECOPUR T-ECOPUR S-ECOPUR G-ECOPUR
	<b>R30</b> 	<b>Valve stem seal with PTFE jacket</b> for low friction, rubber energizer automatically increases preload as it senses leakage. mainly used as valve seal in oil industry/offshore applications.	-20 °C ... +100 °C -25 °C ... +100 °C -20 °C ... +200 °C -25 °C ... +200 °C	0,5 m/s 0,5 m/s 0,5 m/s 0,5 m/s	500 bar (7200 psi) 500 bar (7200 psi) 1000 bar (14500 psi) 1000 bar (14500 psi)	Seal ECORUBBER 2 ECORUBBER-H ECOFLON ECOTAL ECOPAЕК ECOPAЕК Cover ECOFLON ECOTAL ECOPAЕК ECOPAЕК Backup ECOTAL ECOTAL ECOPAЕК ECOPAЕК
	<b>R35</b> 	<b>single acting flange seal</b> flange seal for static applications, suitable for high pressure range. direction of pressurization (from inside or outside) must be indicated when ordering the seal.	-30 °C ... +110 °C -20 °C ... +110 °C -50 °C ... +110 °C -20 °C ... +110 °C -30 °C ... +110 °C -30 °C ... +100 °C -20 °C ... +200 °C -50 °C ... +150 °C -25 °C ... +150 °C -60 °C ... +200 °C	- - - - - - - - - -	800 bar (11600 psi) 800 bar (11600 psi) 800 bar (11600 psi) 800 bar (11600 psi) 800 bar (11600 psi) 250 bar (3600 psi) 250 bar (3600 psi) 250 bar (3600 psi) 250 bar (3600 psi) 250 bar (3600 psi)	ECOPUR H-ECOPUR T-ECOPUR S-ECOPUR G-ECOPUR ECORUBBER 1 ECORUBBER 2 ECORUBBER 3** ECORUBBER H ECOSIL

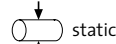
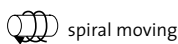
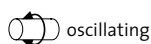
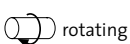
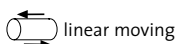

Not bolded symbols: please consult our technical dpmt. for application limitations

\* ECOTAL up to ø260 mm, ECOMID above ø260 mm  
\*\* attention: not suitable for mineral oils !

# Back-up rings

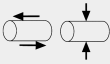
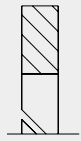
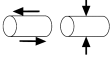
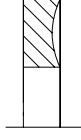
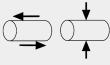
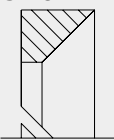
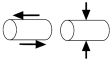
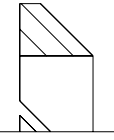
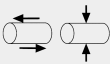
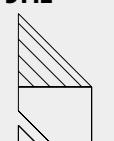
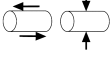
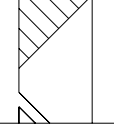
Application	Profile	Description	Temperature	max.speed	Material
	<b>ST8</b> 	<b>back-up ring</b> common inactive back-up ring, mainly used with O-Rings to avoid gap extrusion. split and non split design available.	-50 °C ... +100 °C	-	ECOTAL
			-40 °C ... +100 °C	-	ECOMID*
			-200 °C ... +260 °C	-	ECOFLON 1
			-200 °C ... +260 °C	-	ECOFLON 2
			-30 °C ... +110 °C	-	ECOPUR
			-20 °C ... +110 °C	-	H-ECOPUR
-50 °C ... +110 °C	-	T-ECOPUR			
-30 °C ... +110 °C	-	G-ECOPUR			
	<b>ST9</b> 	<b>back-up ring</b> common inactive back-up ring especially for O-Rings to avoid gap extrusion. split and non split design available.	-200 °C ... +260 °C	-	ECOFLON 1
			-30 °C ... +110 °C	-	ECOPUR
			-20 °C ... +110 °C	-	H-ECOPUR
			-50 °C ... +110 °C	-	T-ECOPUR
			-30 °C ... +110 °C	-	G-ECOPUR
	<b>ST10</b> 	<b>back-up ring</b> standard active back-up ring for piston seal type PD. normally already included in PD-type seal profiles, designed for automatic pressure activation. split and non split design available.	-50 °C ... +100 °C	-	ECOTAL
			-40 °C ... +100 °C	-	ECOMID*
			-200 °C ... +260 °C	-	ECOFLON 2
	<b>ST11</b> 	<b>back-up ring</b> standard active back-up ring for rod seal type PD. normally already included in PD-type seal profiles, designed for automatic pressure activation. split and non split design available.	-50 °C ... +100 °C	-	ECOTAL
			-40 °C ... +100 °C	-	ECOMID*
			-200 °C ... +260 °C	-	ECOFLON 2
	<b>ST12</b> 	<b>back-up ring</b> triangular back-up ring for rod applications, fits in special shaped housings (see seal data sheets). also used as integrated active back-up ring in special high pressure or low friction seal profiles. split and non split design available.	-50 °C ... +100 °C	-	ECOTAL
			-40 °C ... +100 °C	-	ECOMID*
			-200 °C ... +260 °C	-	ECOFLON 2
	<b>ST13</b> 	<b>back-up ring</b> triangular back-up ring for piston applications, fits in special shaped housings (see seal data sheets). also used as integrated active back-up ring in special high pressure or low friction seal profiles. split and non split design available.	-50 °C ... +100 °C	-	ECOTAL
			-40 °C ... +100 °C	-	ECOMID*
			-200 °C ... +260 °C	-	ECOFLON 2

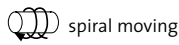
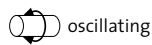
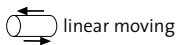





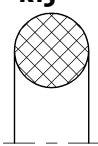
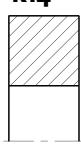

Not bolded symbols: please consult our technical dpmt. for application limitations

\* ECOTAL up to ø260 mm, ECOMID above ø260 mm

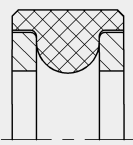
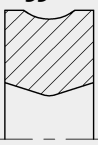
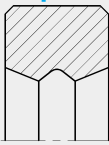
# Static seals

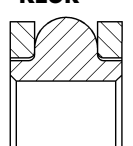
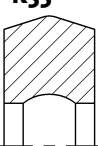
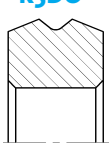
Beside the conventional O-rings and square-rings Seal-Jet® offers a standard range of specialized seals for static applications. Most of below listed profiles fit in standard O-ring-grooves ( housings) and can be substituted easily without any rework of housing dimensions.

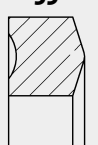
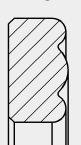
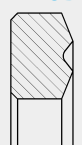
Application	static	Profiles			
<b>universal</b>		<b>R13</b> 	<b>R14</b> 		<b>universal type</b> most common and simple seal profiles with proven reliability in multiple applications in every sector of industry.
<b>inside sealing</b>		<b>S20R</b> 	<b>S35</b> 	<b>R4DI</b> 	<b>inside sealing type</b> interference fit on outside diameter assures stable fit in the housing and reliable performance at all pressures.
<b>outside sealing</b>		<b>K20R</b> 	<b>K35</b> 	<b>R5DO</b> 	<b>outside sealing type</b> interference fit on inside diameter assures stable fit in the housing and reliable performance at all pressures.
<b>axial sealing</b>		<b>R35</b> 	<b>R20</b> 	<b>R20DA</b> 	<b>axial sealing type</b> robust profiles mainly used as flange seals, inside or outside pressurization possible. direction of pressurization (from inside or outside) must be indicated when ordering the seal.

For material data, temperature- and pressure limitations please refer to the respective entries in the profile description.

In addition to our standard range of static seals we certainly do offer special tailor-made static seal profiles to satisfy the very specific needs of every customer, in every industry.

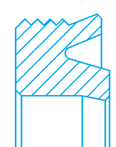
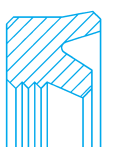
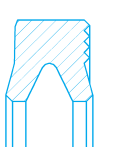
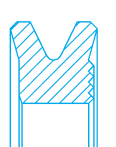
Special application	static	Profiles				
<b>tailormade solutions</b>						these special profiles are examples for our wide and flexible product range.

# Piston seal housing details & recommendations

Indicated dimensions are required to process an order

$\phi D$  ..... outside diameter  
 $\phi d$  ..... inside diameter  
 $L$  ..... groove length

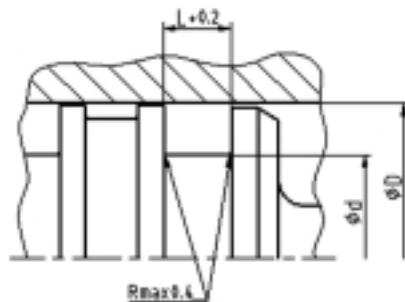

Surface roughness	Rtmax (µm)	Ra (µm)
Sliding surface for PU/RUBBER seals	25	0.1-0.5
Sliding surface for PTFE seals	2	0.05-0.3
Bottom of groove	6.3	1.6
Groove face	15	3
bearing area Tp	> 50%	95%

### Seal housing tolerances

$\phi d$  h10  
 $\phi D$  H9

### Easy ordering procedure

**K1**

**H-ECOPUR**

**160 x 140 x 12**

profile

material

nominal housing dimensions

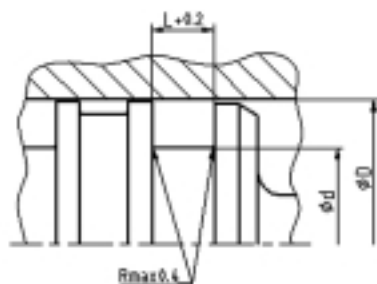

**K1**  
**K2**  
**K3**  
**K4**  
**K5**  
**K6**  
**K7**  
**K20**

**K21**  
**K35**

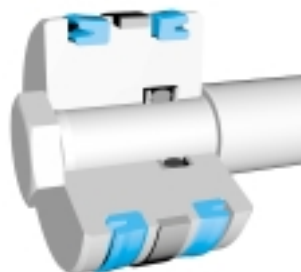

### Main applications:

support- and retaining cylinders  
 standard cylinders

### Advantages:

stable fit in the housing,  
 ultimate sealing effect,  
 wide temperature range

### Standard Materials:

ECOPUR, ECORUBBER (all types)

**K8**  
**K23**

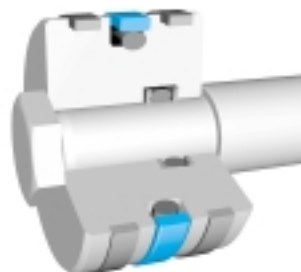
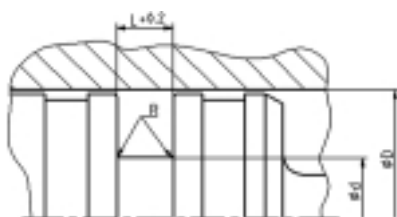

### Main applications:

standard cylinders for positioning  
 functions, mobile hydraulics, etc.

### Advantages:

low friction, no stick-slip, excellent  
 resistance against pressure shocks

### Standard Materials:

ECOFLOX / NBR or ECOFLOX / Viton

**K9**  
**K17**

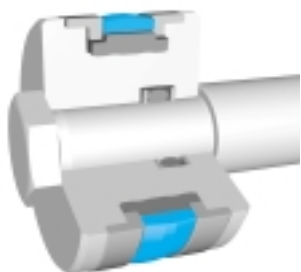
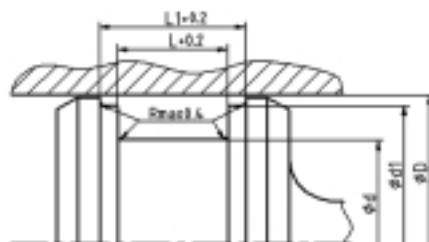

### Main applications:

support- and retaining cylinders  
 standard cylinders

### Advantages:

excellent static and dynamic sealing  
 capacity, integrated guide rings

### Standard Materials:

ECOPUR / ECORUBBER / ECOTAL

### housing recommendations

single acting piston seals  
lip type (u-cup) seals  
compact seals

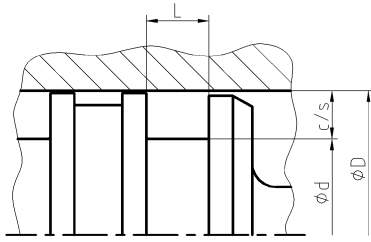

The listing below is our suggestion for standard housing dimensions. Please note that we are able to produce those profiles to your specific need or any non standard housing.

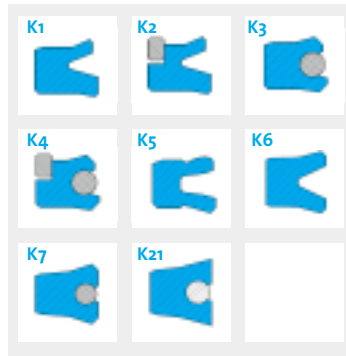

$\phi D$	$\phi d$	L	c/s
5 - 24,9	$\phi D-8$	6	4
25 - 49,9	$\phi D-10$	7	5
50 - 74,9	$\phi D-12$	8	6
75 - 149,9	$\phi D-16$	10	8
150 - 299,9	$\phi D-20$	12	10
300 - 500	$\phi D-24$	18	12
500 - 750	$\phi D-30$	20	15
> 750	$\phi D-40$	26	20

### housing recommendations

single/double acting piston seals  
o-ring activated PTFE (PU) seals

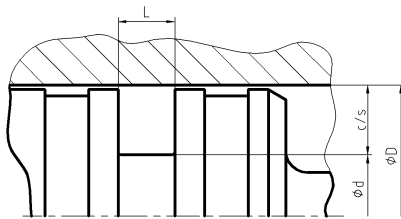

The listing below is our suggestion for standard housing dimensions. Please note that we are able to produce those profiles to your specific need or any non standard housing.

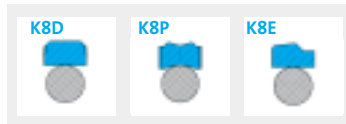

$\phi D$	$\phi d$	L	c/s
8-14,9	$\phi D-4,9$	2,2	2,45
15-39,9	$\phi D-7,5$	3,2	3,75
40-79,9	$\phi D-11$	4,2	5,5
80-132,9	$\phi D-15,5$	6,3	7,75
133 - 329,9	$\phi D-21$	8,1	10,5
330 - 669,9	$\phi D-24,5$	8,1	12,25
670 - 1.000	$\phi D-28$	9,5	14*
> 1.000	$\phi D-28$	9,5	14*

\* only profiles K8D and K8E, not for profile K8P

### housing recommendations

double acting piston seals  
compact type

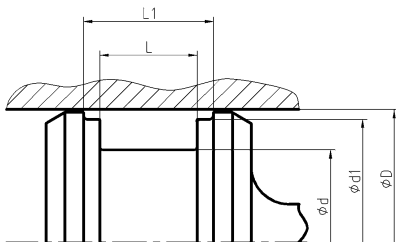

The listing below is our suggestion for standard housing dimensions. Please note that we are able to produce those profiles to your specific need or any non standard housing.



$\phi D$	$\phi d$	$\phi d1$	L*	L1*
20 - 49,9	$\phi D-10$	$\phi D-3$	12,5	20,5
50 - 79,9	$\phi D-15$	$\phi D-4$	20	28
80 - 149,9	$\phi D-20$	$\phi D-5$	25	36
150 - 399,9	$\phi D-25$	$\phi D-6$	32	46
400 - 750	$\phi D-30$	$\phi D-8$	36	50
>750	$\phi D-40$	$\phi D-8$	40	54

\* not valid for profile K9H

# Rod Seal housing details & recommendations

Indicated dimensions are required to process an order

$\phi D$  ..... outside diameter  
 $\phi d$  ..... inside diameter  
 L ..... groove length

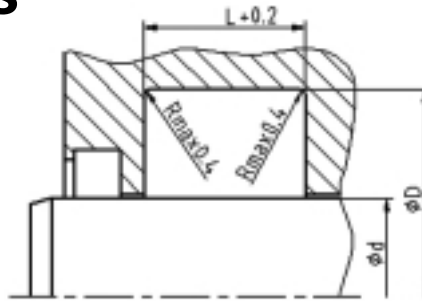

Surface roughness	Rtmax (µm)	Ra (µm)
Sliding surface for PU/RUBBER seals	25	0.1 - 0.5
Sliding surface for PTFE seals	2	0.05 - 0.3
Bottom of groove	6.3	1.6
Groove face	15	3
bearing area Tp	> 50%	95%

Seal housing tolerances	
$\phi d$	f8
$\phi D$	H10

## Easy ordering procedure

S1  
profile

ECOPUR  
material

60 x 75 x 10  
nominal housing dimensions

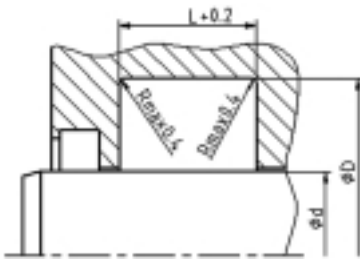

S1  
S2  
S3  
S4  
S5  
S6  
S7  
S8

S17  
S18  
S19  
S35

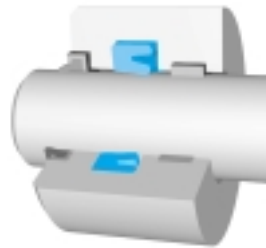

### Main applications:

standard cylinders  
light & standard hydraulic applications

### Advantages:

stable fit in the housing, ultimate sealing effect, wide temperature range, good backpumping ability

### Standard Materials:

ECOPUR, ECORUBBER

S9

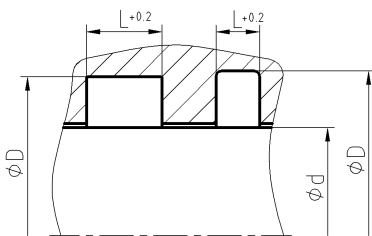

### Main applications:

earth moving equipment,  
heavy hydraulics

### Advantages:

excellent resistance against pressure shocks, long lifetime

### Standard Materials:

S9: ECOFLON / NBR or ECOFLON / VITON  
S1: ECOPUR or ECORUBBER

S1012  
S1315

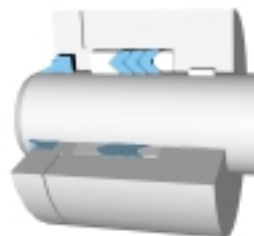
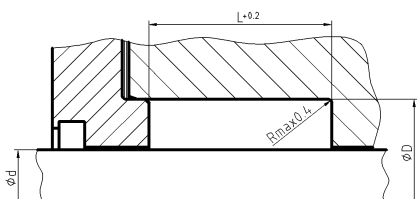

### Main applications:

heavy industry hydraulics, presses

### Advantages:

suitable for old, worn rods,  
splitted version for easy installation available

### Standard Materials:

ECOPUR / ECOTAL

### housing recommendations

single acting rod seals  
lip type (u-cup) seals  
compact seals

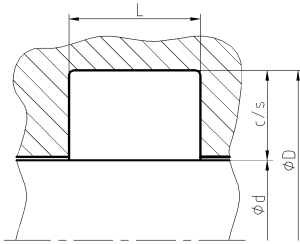

The listing below is our suggestion for standard housing dimensions. Please note that we are able to produce those profiles to your specific need or any non standard housing.

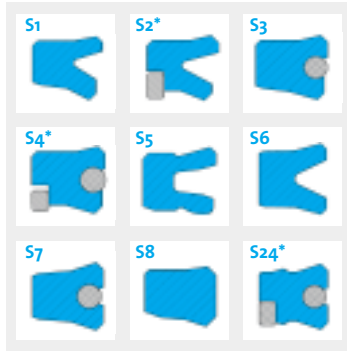

$\phi d$	$\phi D$	L	c/s
5 - 24,9 *	$\phi d+8$	6,3	4
25 - 49,9	$\phi d+10$	8	5
50 - 149,9	$\phi d+15$	10	7,5
150 - 299,9	$\phi d+20$	14	10
300 - 499,9	$\phi d+25$	17	12,5
500 - 699,9	$\phi d+30$	25	15
700 - 1.000	$\phi d+40$	32	20
> 1.000	$\phi d+40$	32	20

### housing recommendations

single/double acting rod seals  
O-ring activated PTFE (PU) seals

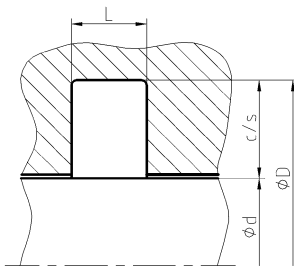

The listing below is our suggestion for standard housing dimensions. Please note that we are able to produce those profiles to your specific need or any non standard housing.



$\phi d$	$\phi D$	L	c/s
5 - 7,9	$\phi d+4,9$	2,2	2,45
8 - 18,9	$\phi d+7,3$	3,2	3,65
19 - 37,9	$\phi d+10,7$	4,2	5,35
38 - 199,9	$\phi d+15,1$	6,3	7,55
200 - 255,9	$\phi d+20,5$	8,1	10,25
256 - 649,9	$\phi d+24$	8,1	12
650 - 1.000	$\phi d+27,3$	9,5	13,65
> 1.000	$\phi d+27,3$	9,5	13,65

### housing recommendations

single acting rod seals  
chevron packings

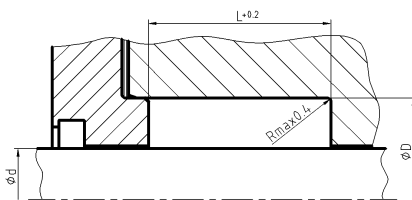

The listing below is our suggestion for standard housing dimensions. Please note that we are able to produce those profiles to your specific need or any non standard housing.



$\phi d$	$\phi D$	L	c/s
10 - 39,9	$\phi d+10$	16	5
40 - 74,9	$\phi d+15$	25	7,5
75 - 149,9	$\phi d+20$	32	10
150 - 199,9	$\phi d+25$	40	12,5
200 - 300	$\phi d+30$	50	15
> 300	$\phi d+40$	63	20

\* Restrictions in minimum diameter for profiles with back-up rings. Please consult our technical dpmt. for exact limitations.

# Wiper Seal housing details & recommendations

Indicated dimensions are required to process an order

$\phi D$  ..... outside diameter  
 $\phi d$  ..... inside diameter (rod)  
 L ..... groove length  
 H ..... total wiper height

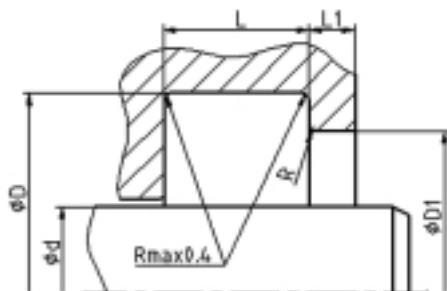

	Surface roughness	Rtmax ( $\mu m$ )	Ra ( $\mu m$ )
Sliding surface for PU/RUBBER seals		25	0.1-0.5
Sliding surface for PTFE seals		2	0.05-0.3
Bottom of groove		6.3	1.6
Groove face		15	3
bearing area Tp		>50%	95%
<b>Seal housing tolerances</b>			
$\phi D_1$	H11	L<10 mm	+0,2
$\phi D$	H11	L>10 mm	+0,3

## Easy ordering procedure

<b>A1</b>	<b>S-ECOPUR</b>	<b>60 x 68 x 4/7</b>
profile	material	nominal housing dimensions / total wiper height

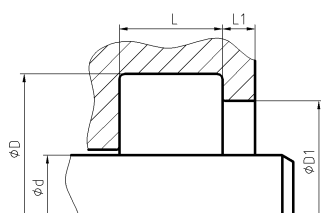

**A1**  
**A4**

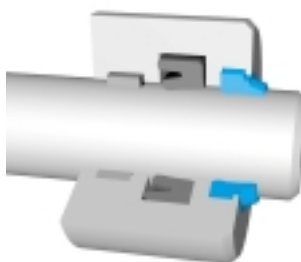

### Main applications:

standard wiper for hydraulic

### Advantages:

easy installation (snap-in)  
 excellent wear resistance,  
 technically accurate closure

### Standard Materials:

ECOPUR / ECORUBBER

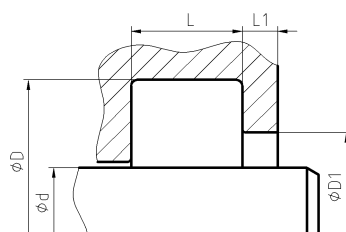

**A11**  
**A2**  
**A5**  
**A12**

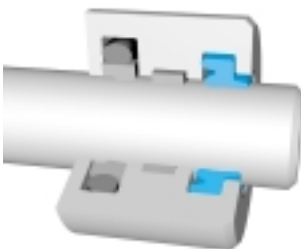

### Main applications:

in combination with O-ring activated PTFE rod seals (S9)

### Advantages:

excellent wear resistance,  
 double acting function

### Standard Materials:

ECOPUR / ECORUBBER

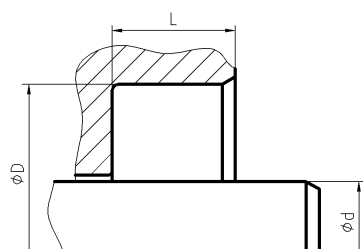

**A3**  
**A6**

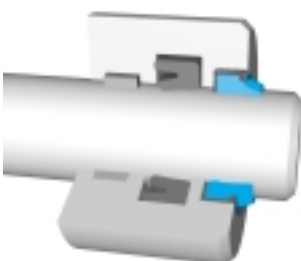

### Main applications:

standard hydraulic applications,  
 pressfit for axially open housings

### Advantages:

excellent wear resistance,  
 plastic retainer ring, no oxidation problem between retainer and housing

### Standard Materials:

ECOPUR+ECOTAL / ECORUBBER+ECOTAL

### housing recommendations

#### single acting wipers

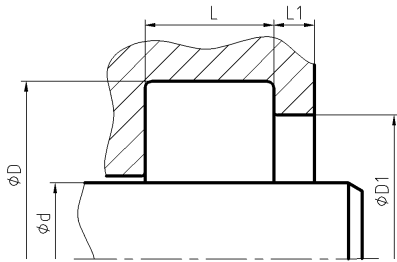

The listing below is our suggestion for standard housing dimensions. Please note that we are able to produce those profiles to your specific need or any non standard housing.

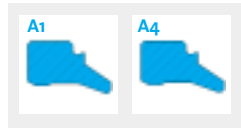

$\phi d$	$\phi D$	$\phi D1$	L	L1	H*
6 - 100	$\phi d+8$	$\phi d+6$	4	1	7
100,1 - 149,9	$\phi d+12$	$\phi d+9$	5,5	1,5	10
150	$\phi d+15$	$\phi d+11$	6,5	2	13

\* H = total wiper height

### housing recommendations

#### single/double acting wipers

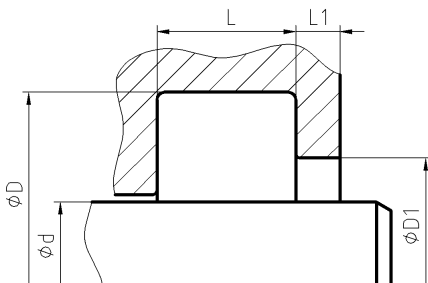

The listing below is our suggestion for standard housing dimensions. Please note that we are able to produce those profiles to your specific need or any non standard housing.



$\phi d$	$\phi D$	$\phi D1$	L	L1	H*
6 - 49,9	$\phi d+8$	$\phi d+4$	5	min. 2	8
50 - 99,9	$\phi d+10$	$\phi d+5$	6	min. 2	9,7
100	$\phi d+15$	$\phi d+7,5$	8,5	min. 2	13

\* H = total wiper height

### housing recommendations

#### single acting wipers

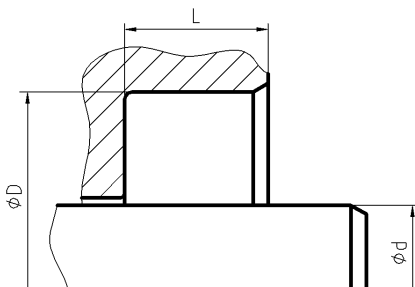

The listing below is our suggestion for standard housing dimensions. Please note that we are able to produce those profiles to your specific need or any non standard housing.

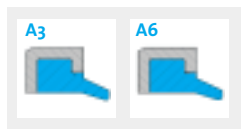

$\phi d$	$\phi D$	L	H*
6 - 9,9	$\phi d+8$	5	8
10 - 99,9	$\phi d+10$	7	10
100 - 200	$\phi d+15$	9	12
> 200	$\phi d+20$	12	16

\* H = total wiper height

# Rotary Seal housing details & recommendations

Indicated dimensions are required to process an order

$\phi D$  ..... outside diameter  
 $\phi d$  ..... inside diameter (shaft)  
 $L$  ..... groove length

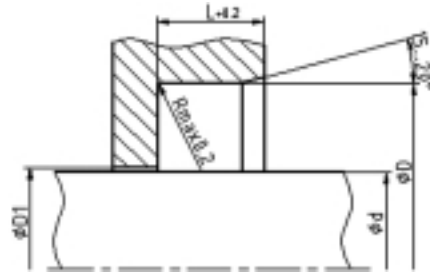

Surface roughness	Rtmax ( $\mu\text{m}$ )	Ra ( $\mu\text{m}$ )
Sliding surface for PU/RUBBER seals	25	0.1-0.5
Sliding surface for PTFE seals	2	0.05-0.3
Bottom of groove	6.3	1.6
Groove face	15	3
bearing area Tp	>50%	95%

## Seal housing tolerances

$\phi d$  f8  
 $\phi D$  H8

### Easy ordering procedure

R1  
profile

ECORUBBER 1 / ECOTAL  
material

60 x 80 x 10

nominal housing dimensions

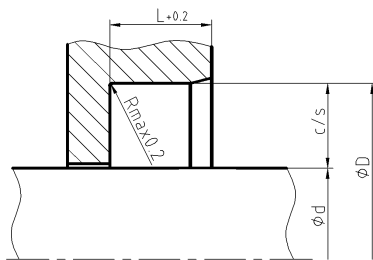

R1  
R2

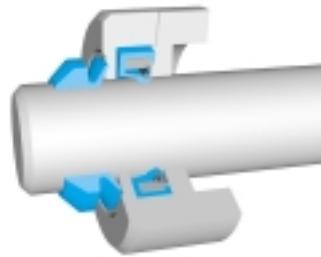

**Main applications:**  
bearing protection

**Advantages:**  
good adaptation possibilities for diverse temperatures and media

**Standard Materials:**  
ECOPUR, ECORUBBER / ECOTAL, Aluminium

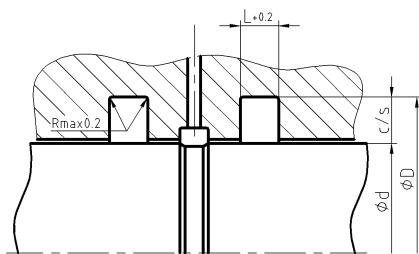

R9

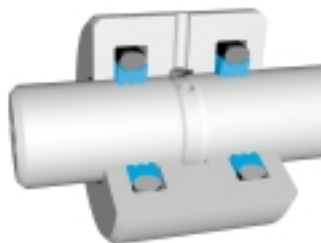

**Main applications:**  
rotary pivots

**Advantages:**  
for high pressure

**Standard Materials:**  
ECOFLOX + NBR or Viton

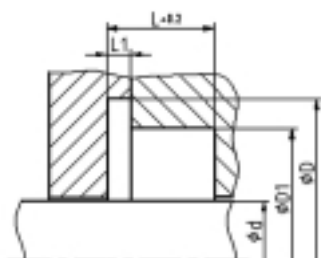

R19

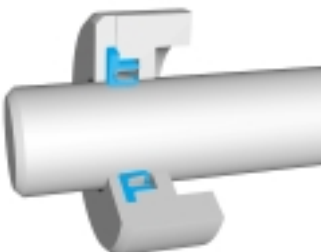

**Main applications:**  
bearing protection for chemical and pharma industries

**Advantages:**  
low friction, good chemical and thermal resistance, suitable for high speed

**Standard Materials:**  
ECOFLOX, stainless steel spring

**housing recommendations**

**single acting rotary seals  
oil seals / radial shaft seals**

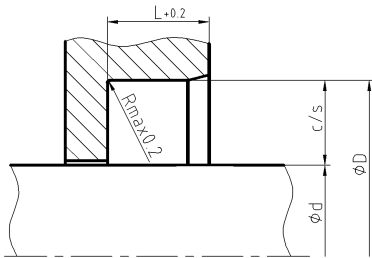

The listing below is our suggestion for standard housing dimensions. Please note that we are able to produce those profiles to your specific need or any non standard housing.



$\phi d$	$\phi D$	L	c/s
6 - 59,9	$\phi d+12$	7	6
60 - 139,9	$\phi d+15$	8	7,5
140 - 299,9	$\phi d+20$	10	10
300 - 499,9	$\phi d+30$	12	15
500 - 800	$\phi d+40$	20	20
> 800	$\phi d+50$	22	25

**housing recommendations**

**double acting rotary seals  
O-ring activated PTFE seals**

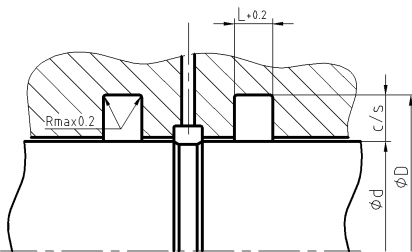

The listing below is our suggestion for standard housing dimensions. Please note that we are able to produce those profiles to your specific need or any non standard housing.



$\phi d$	$\phi D$	L	c/s
6 - 18,9	$\phi d+4,9$	2,2	2,45
19 - 37,9	$\phi d+7,5$	3,2	3,75
38 - 199,9	$\phi d+11$	4,2	5,5
200 - 255,9	$\phi d+15,5$	6,3	7,75
256 - 649,9	$\phi d+21$	8,1	10,5
>650	$\phi d+28$	9,5	14

**housing recommendations**

**single acting rotary seals  
Spring activated PTFE seals**

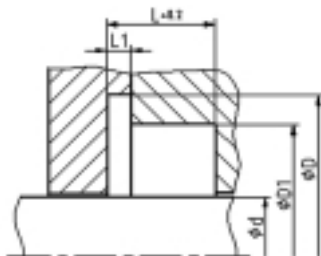

The listing below is our suggestion for standard housing dimensions. Please note that we are able to produce those profiles to your specific need or any non standard housing.



$\phi d$	$\phi D$	$\phi D1$	L	L1
5 - 19,9	$\phi d+9$	$\phi d+5$	3,6	0,85
20 - 39,9	$\phi d+12,5$	$\phi d+7$	4,8	1,35
40 - 399,9	$\phi d+17,5$	$\phi d+10,5$	7,1	1,8
400	$\phi d+22$	$\phi d+14$	9,5	2,8

# O-ring housing details & recommendations

## O-Ring housing recommendations for static applications

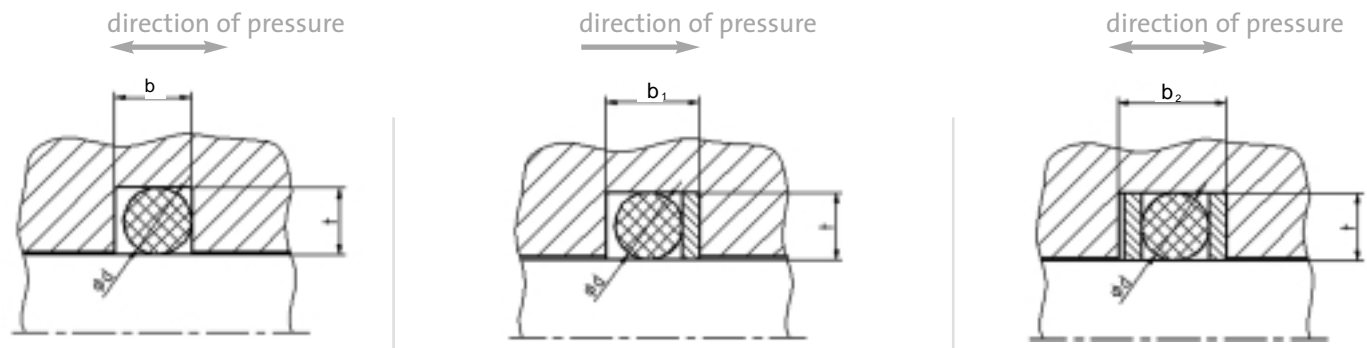

cord (mm)	groove (mm)	without back-up ring (mm)	one back-up ring (mm)	2 back-up rings (mm)	recommended back-up ring width (mm)
$\varnothing d$	$t \pm 0,05$	$b + 0,25$	$b_1 + 0,25$	$b_2 + 0,25$	
1,5	1,10	2,1	3,1	4,1	1,0
1,78	1,35	2,5	3,5	4,5	1,0
2,00	1,56	2,7	4,2	5,7	1,5
2,50	2,05	3,3	4,8	6,3	1,5
2,62	2,18	3,5	5,0	6,5	1,5
3,00	2,52	3,9	5,4	6,9	1,5
3,50	3,00	4,4	5,9	7,4	1,5
3,53	3,00	4,4	5,9	7,4	1,5
4,00	3,40	5,0	6,7	8,4	1,7
5,00	4,25	6,3	8,0	9,7	1,7
5,33	4,53	6,7	8,4	10,1	1,7
5,70	4,85	7,1	9,1	11,1	2,0
6,00	5,10	7,5	9,5	11,5	2,0
6,99	5,94	8,8	10,8	12,8	2,0
7,00	5,95	8,8	10,8	12,8	2,0
8,00	6,80	10,0	12,5	15,0	2,5
10,00	8,50	12,5	15,0	17,5	2,5

## Guide ring housing details and recommendations for dynamic applications

Our standard guide rings are available as 45°-splitted versions. Those can be ordered as well as endless -, 90°-splitted versions or yard ware.

### housing recommendations

guide rings  
rod

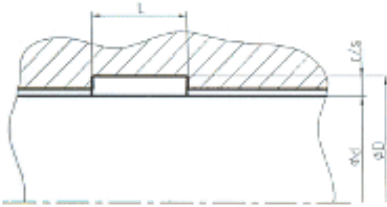

The listing below is our suggestion for standard housing dimensions. [Please note that we are able to produce those profiles to your specific need or any non standard housing.](#)



$\varnothing d$	$\varnothing D$	L	c/s
6 - 29,9	$\varnothing d+3$	4	1,5
30 - 49,9	$\varnothing d+3$	5,6	1,5
50 - 99,9	$\varnothing d+5$	9,7	2,5
100 - 799,9	$\varnothing d+5$	15	2,5
800 - 1.000	$\varnothing d+8$	25	4
>1.000	$\varnothing d+8$	25	4

### housing recommendations

guide rings  
piston

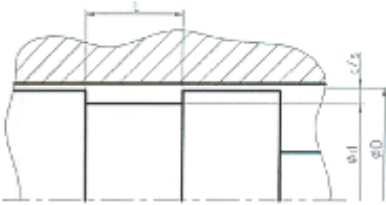

The listing below is our suggestion for standard housing dimensions. [Please note that we are able to produce those profiles to your specific need or any non standard housing.](#)



$\varnothing d$	$\varnothing D$	L	c/s
6 - 29,9	$\varnothing D-3$	4	1,5
30 - 49,9	$\varnothing D-3$	5,6	1,5
50 - 99,9	$\varnothing D-5$	9,7	2,5
100 - 799,9	$\varnothing D-5$	15	2,5
800 - 1.000	$\varnothing D-8$	25	4
>1.000	$\varnothing D-8$	25	4